



LG

<http://eic.lgservice.com>

SXS REFRIGERATOR

SERVICE MANUAL

CAUTION

**PLEASE READ CAREFULLY THE SAFETY PRECAUTIONS OF THIS BOOK
BEFORE CHECKING OR OPERATING THE REFRIGERATOR.**

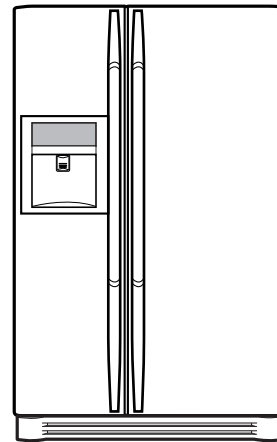
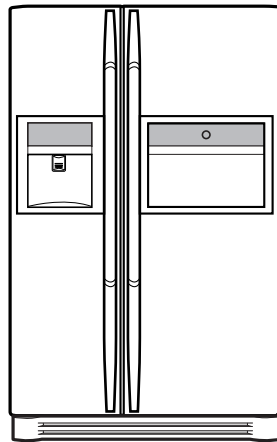

**MODEL: GR-P227/L227
GR-P257/L257**

COLOR: TITANIUM

CONTENTS

WARNINGS AND PRECAUTIONS FOR SAFETY	3
SPECIFICATIONS.....	4
PARTS IDENTIFICATION	6
HOW TO INSTALL THE REFRIGERATOR	10
HOW TO ADJUST DOOR HEIGHT OF THE REFRIGERATOR	10
HOW TO INSTALL WATER PIPE	11
HOW TO CONTROL THE AMOUNT OF WATER SUPPLIED TO THE ICEMAKER	15
MICOM FUNCTION	16
EXPLANATION FOR MICOM CIRCUIT.....	26
EXPLANATION FOR PWB CIRCUIT	26
ICE MAKER AND DISPENSER OPERATION PRINCIPLE AND REPAIR METHOD.....	41
OPERATION PRINCIPLE.....	41
ICEMAKER FUNCTIONS	42
DEFECT DIAGNOSIS FUNCTION.....	43
CIRCUIT	44
TROUBLE DIAGNOSIS.....	45
TROUBLE SHOOTING	45
FAULTS	55
COOLING CYCLE HEAVY REPAIR.....	72
HOW TO DEAL WITH CLAIMS.....	79
HOW TO DISASSEMBLE AND ASSEMBLE	84
DOOR.....	84
HANDLE	85
SHROUD, GRILLE FAN	85
WATER VALVE DISASSEMBLY METHOD	86
FAN AND FAN MOTOR DISASSEMBLY METHOD	86
DISPENSER.....	87
EXPLODED VIEW	89

WARNINGS AND PRECAUTIONS FOR SAFETY

Please observe the following safety precautions in order to use safely and correctly the refrigerator and to prevent accident and danger during repair.

1. Be care of an electric shock. Disconnect power cord from wall outlet and wait for more than three minutes before replacing PWB parts. Shut off the power whenever replacing and repairing electric components.
2. When connecting power cord, please wait for more than five minutes after power cord was disconnected from the wall outlet.
3. Please check if the power plug is pressed down by the refrigerator against the wall. If the power plug was damaged, it may cause fire or electric shock.
4. If the wall outlet is over loaded, it may cause fire. Please use its own individual electrical outlet for the refrigerator.
5. Please make sure the outlet is properly earthed, particularly in wet or damp area.
6. Use standard electrical components when replacing them.
7. Make sure the hook is correctly engaged. Remove dust and foreign materials from the housing and connecting parts.
8. Do not fray, damage, machine, heavily bend, pull out, or twist the power cord.
9. Please check the evidence of moisture intrusion in the electrical components. Replace the parts or mask it with insulation tapes if moisture intrusion was confirmed.
10. Do not touch the icemaker with hands or tools to confirm the operation of geared motor.
11. Do not let the customers repair, disassemble, and reconstruct the refrigerator for themselves. It may cause accident, electric shock, or fire.
12. Do not store flammable materials such as ether, benzene, alcohol, chemicals, gas, or medicine in the refrigerator.
13. Do not put flower vase, cup, cosmetics, chemicals, etc., or container with full of water on the top of the refrigerator.
14. Do not put glass bottles with full of water into the freezer. The contents shall freeze and break the glass bottles.
15. When you scrap the refrigerator, please disconnect the door gasket first and scrap it where children are not accessible.

SPECIFICATIONS

1. Ref No. : GR-P227

ITEMS	SPECIFICATIONS	ITEMS	SPECIFICATIONS
DIMENSIONS (mm)	894(W)x790(D)x1753(H)	FIRST DEFROST	4 - 5 Hours
NET WEIGHT (kg)	132	DEFROST CYCLE	13 - 15 Hours
COOLING SYSTEM	Fan Cooling	DEFROSTING DEVICE	Heater, Sheath
TEMPERATURE CONTROL	Micom Control	ANTI SWEAT HEATER	Dispenser Duct Door Heater
DEFROSTING SYSTEM	Full Automatic		Dispenser Heater
	Heater Defrost		Home Bar Heater
INSULATION	Cyclo-Pentane	ANTI-FREEZING HEATER	Damper Heater
COMPRESSOR	P.T.C. Starting Type	FREEZER LAMP	40W (1 EA)
EVAPORATOR	Fin Tube Type	REFRIGERATOR LAMP	40W (1 EA) / 30W (1 EA)
CONDENSER	Wire Condenser		
REFRIGERANT	R134a (180g)		
LUBRICATING OIL	FREOL @ 10G (310 cc)		
CAPILLARY TUBE	ID 0.83		
DRIER	MOLECULAR SIEVE XH-7		

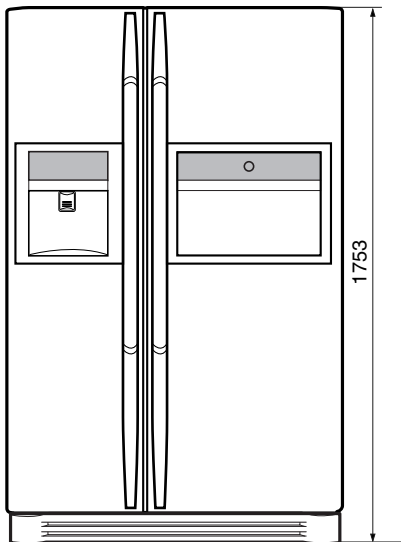

<Front View>

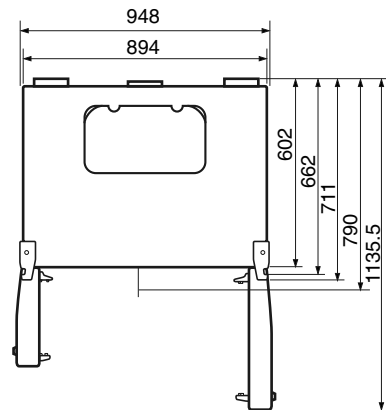

<Plane View>

SPECIFICATIONS

2. Ref No. : GR-L227

ITEMS	SPECIFICATIONS	ITEMS	SPECIFICATIONS
DIMENSIONS (mm)	894(W)x790(D)x1753(H)	DRIER	MOLECULAR SIEVE XH-7
NET WEIGHT (kg)	132	FIRST DEFROST	4 - 5 Hours
COOLING SYSTEM	Fan Cooling	DEFROST CYCLE	13 - 15 Hours
TEMPERATURE CONTROL	Micom Control	DEFROSTING DEVICE	Heater, Sheath
DEFROSTING SYSTEM	Full Automatic	ANTI SWEAT HEATER	Dispenser Duct Door Heater
	Heater Defrost		Dispenser Heater
INSULATION	Cyclo-Pentane	ANTI-FREEZING HEATER	Damper Heater
COMPRESSOR	P.T.C. Starting Type	FREEZER LAMP	40W (1 EA)
EVAPORATOR	Fin Tube Type	REFRIGERATOR LAMP	40W (1 EA) / 30W (1 EA)
CONDENSER	Wire Condenser		
REFRIGERANT	R134a (180g)		
LUBRICATING OIL	FREOL @ 10G (310 cc)		
CAPILLARY TUBE	ID 0.83		

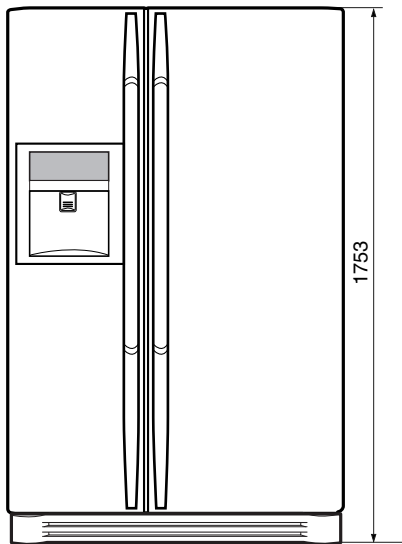

<Front View>

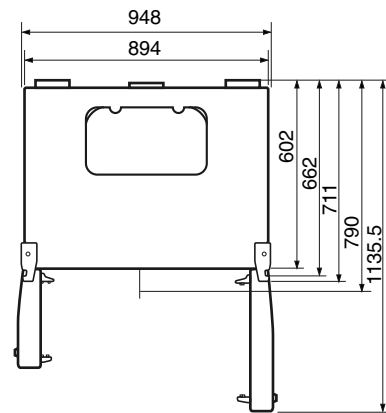

<Plane View>

SPECIFICATIONS

1. Ref No. : GR-P257

ITEMS	SPECIFICATIONS	ITEMS	SPECIFICATIONS
DIMENSIONS (mm)	894(W)x875(D)x1753(H)	FIRST DEFROST	4 - 5 Hours
NET WEIGHT (kg)	132	DEFROST CYCLE	13 - 15 Hours
COOLING SYSTEM	Fan Cooling	DEFROSTING DEVICE	Heater, Sheath
TEMPERATURE CONTROL	Micom Control	ANTI SWEAT HEATER	Dispenser Duct Door Heater
DEFROSTING SYSTEM	Full Automatic		Dispenser Heater
	Heater Defrost		Home Bar Heater
INSULATION	Cyclo-Pentane	ANTI-FREEZING HEATER	Damper Heater
COMPRESSOR	P.T.C. Starting Type	FREEZER LAMP	40W (1 EA)
EVAPORATOR	Fin Tube Type	REFRIGERATOR LAMP	40W (1 EA) / 30W (1 EA)
CONDENSER	Wire Condenser		
REFRIGERANT	R134a (180g)		
LUBRICATING OIL	FREOL @ 10G (310 cc)		
CAPILLARY TUBE	ID 0.83		
DRIER	MOLECULAR SIEVE XH-7		

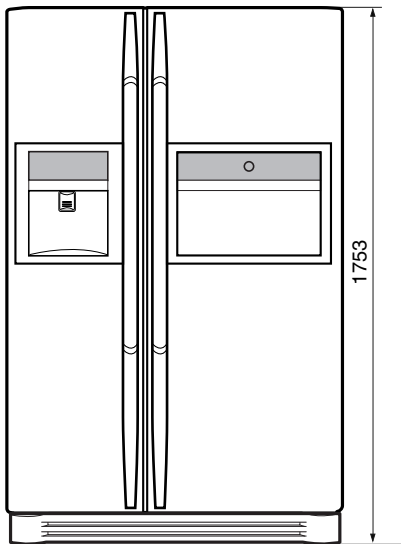

<Front View>

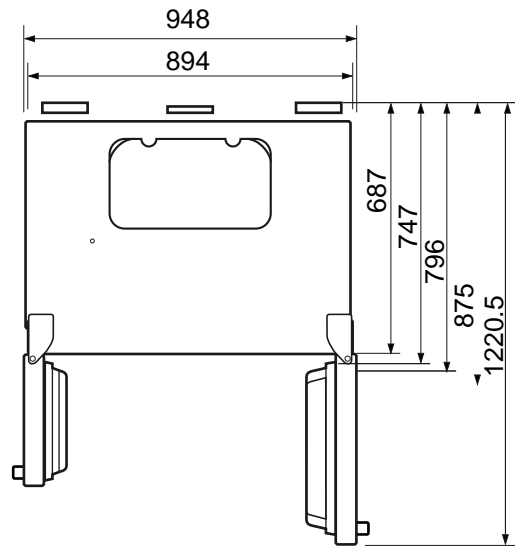

<Plane View>

SPECIFICATIONS

2. Ref No. : GR-L257

ITEMS	SPECIFICATIONS	ITEMS	SPECIFICATIONS
DIMENSIONS (mm)	894(W)x875(D)x1753(H)	DRIER	MOLECULAR SIEVE XH-7
NET WEIGHT (kg)	132	FIRST DEFROST	4 - 5 Hours
COOLING SYSTEM	Fan Cooling	DEFROST CYCLE	13 - 15 Hours
TEMPERATURE CONTROL	Micom Control	DEFROSTING DEVICE	Heater, Sheath
DEFROSTING SYSTEM	Full Automatic	ANTI SWEAT HEATER	Dispenser Duct Door Heater
	Heater Defrost		Dispenser Heater
INSULATION	Cyclo-Pentane	ANTI-FREEZING HEATER	Damper Heater
COMPRESSOR	P.T.C. Starting Type	FREEZER LAMP	40W (1 EA)
EVAPORATOR	Fin Tube Type	REFRIGERATOR LAMP	40W (1 EA) / 30W (1 EA)
CONDENSER	Wire Condenser		
REFRIGERANT	R134a (180g)		
LUBRICATING OIL	FREOL @ 10G (310 cc)		
CAPILLARY TUBE	ID 0.83		

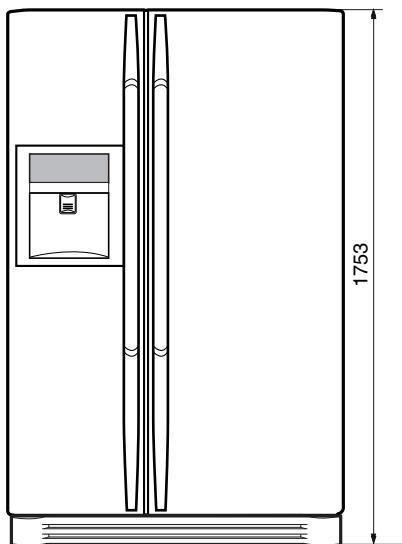

<Front View>

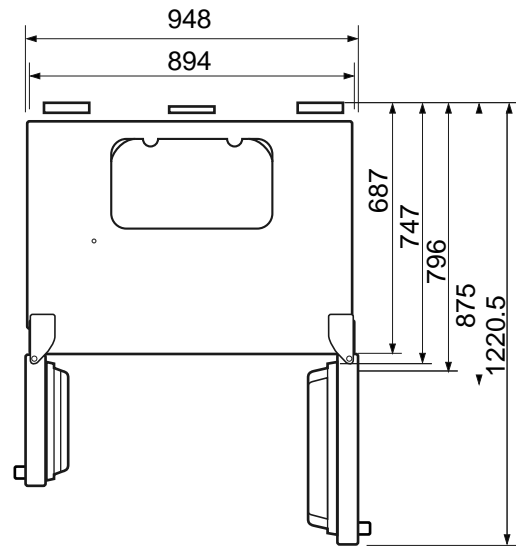

<Plane View>

PARTS IDENTIFICATION

1. Ref No. : GR-P227/GR-P257 (INTERNAL FILTER)

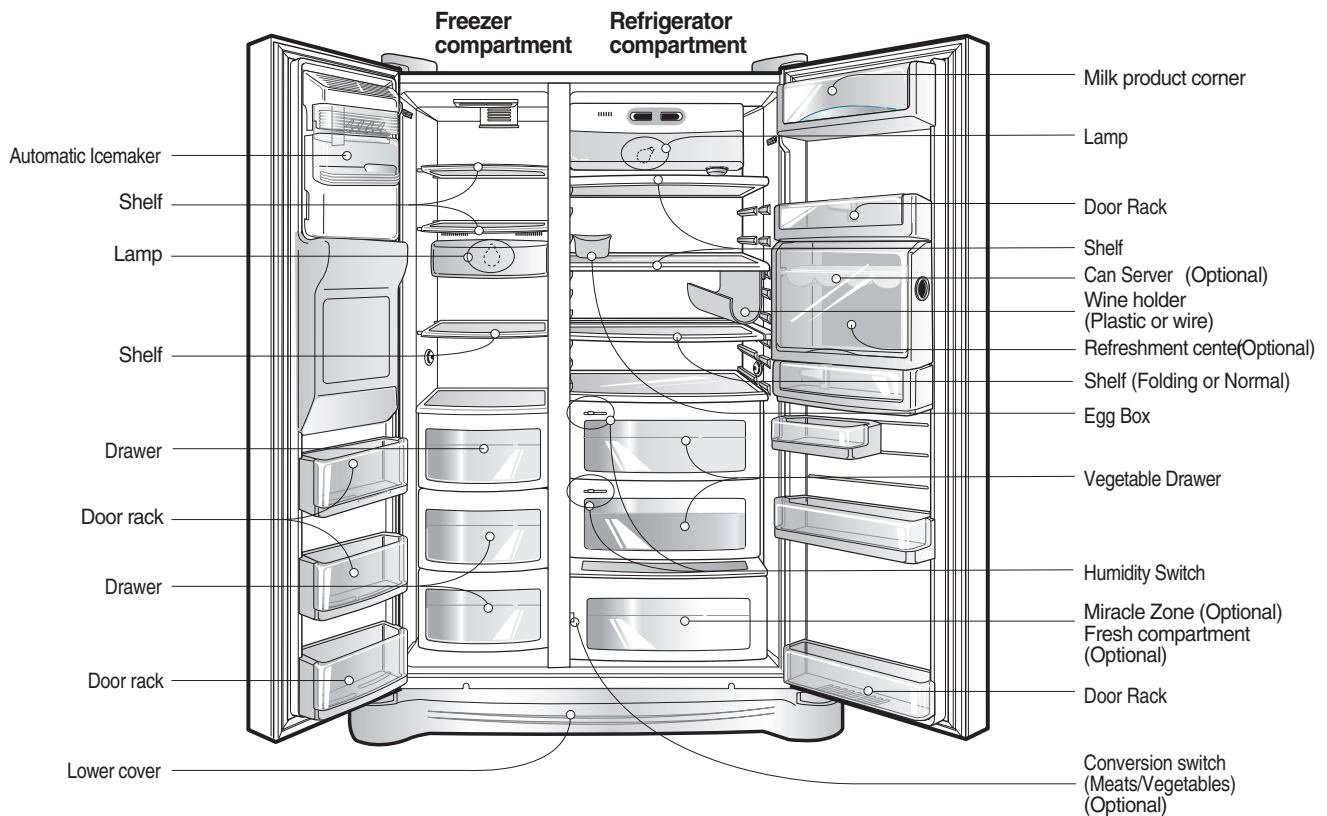
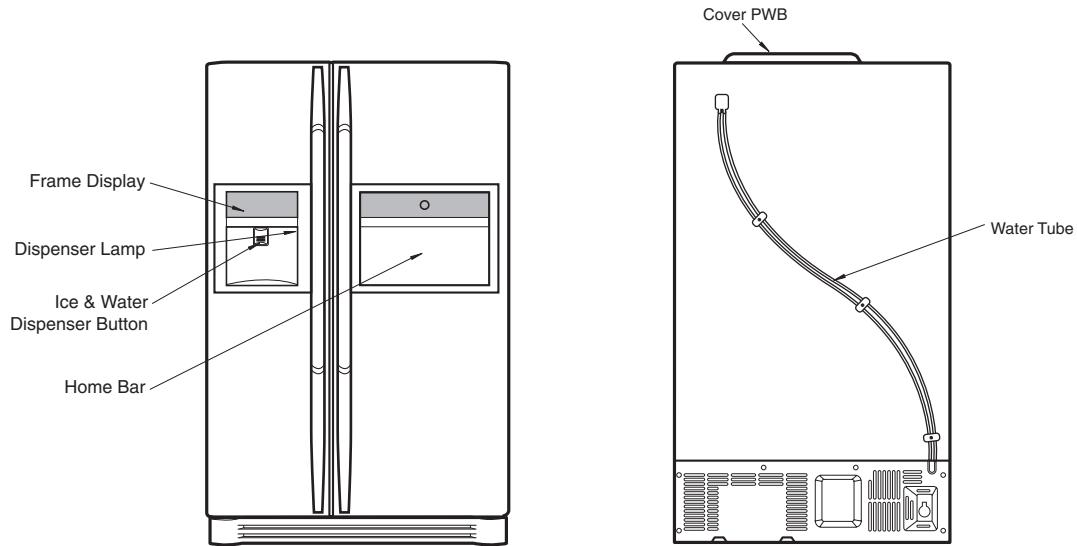

PARTS IDENTIFICATION

2. Ref No. : GR-P227/GR-P257 (EXTERNAL FILTER)

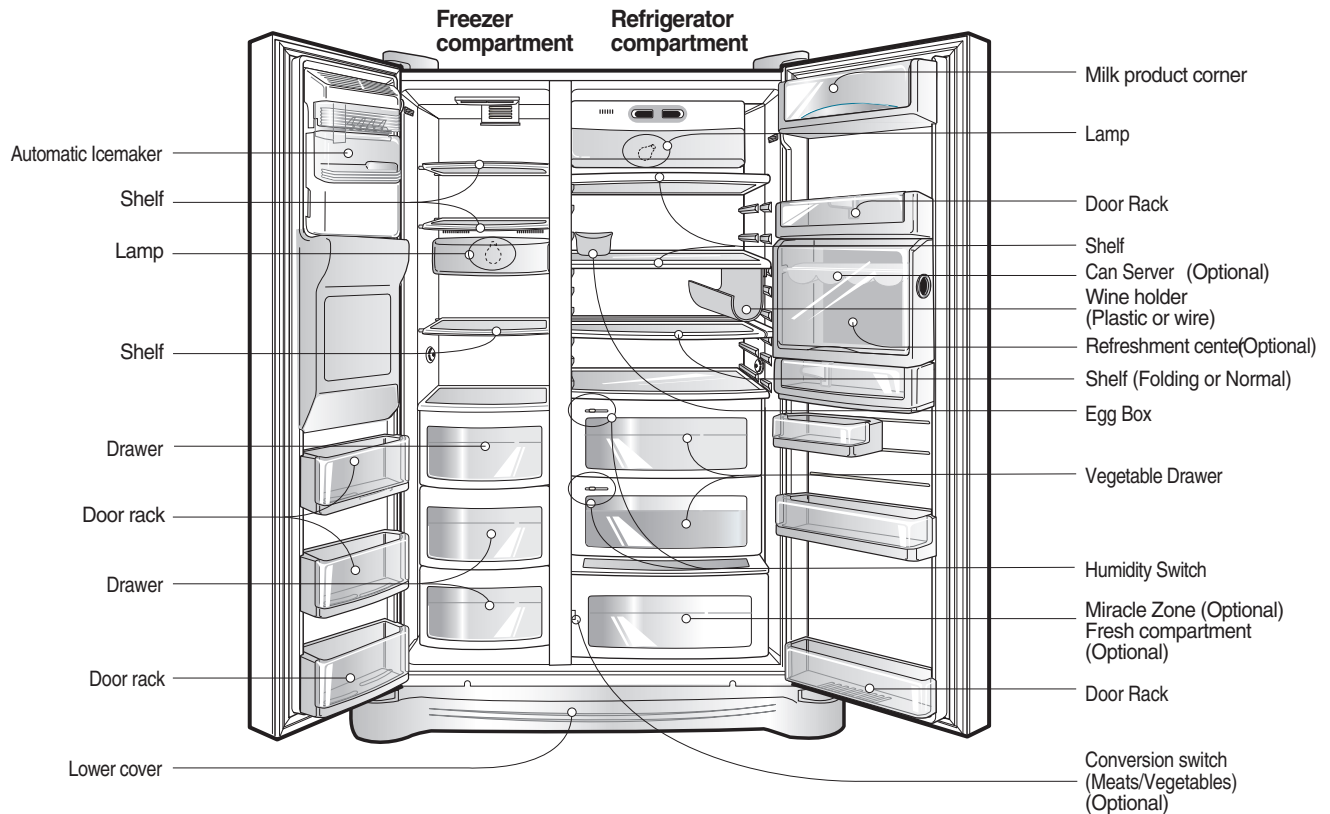
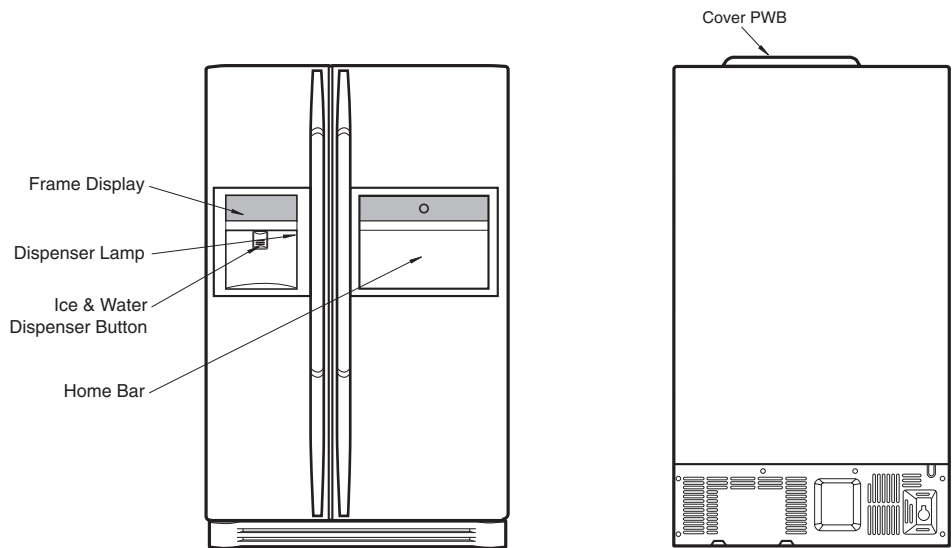

PARTS IDENTIFICATION

3. Ref No. : GR-P227/GR-P257 (INTERNAL FILTER)

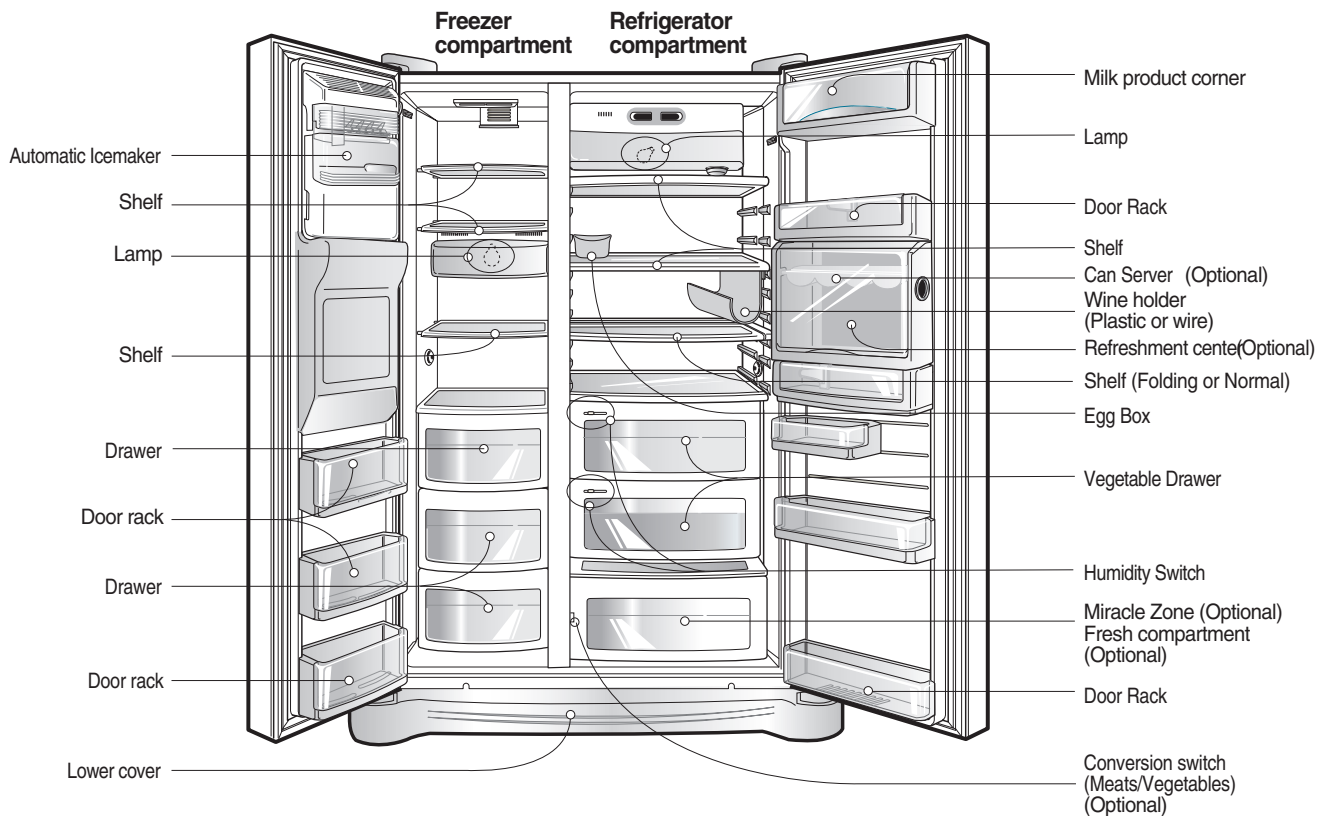
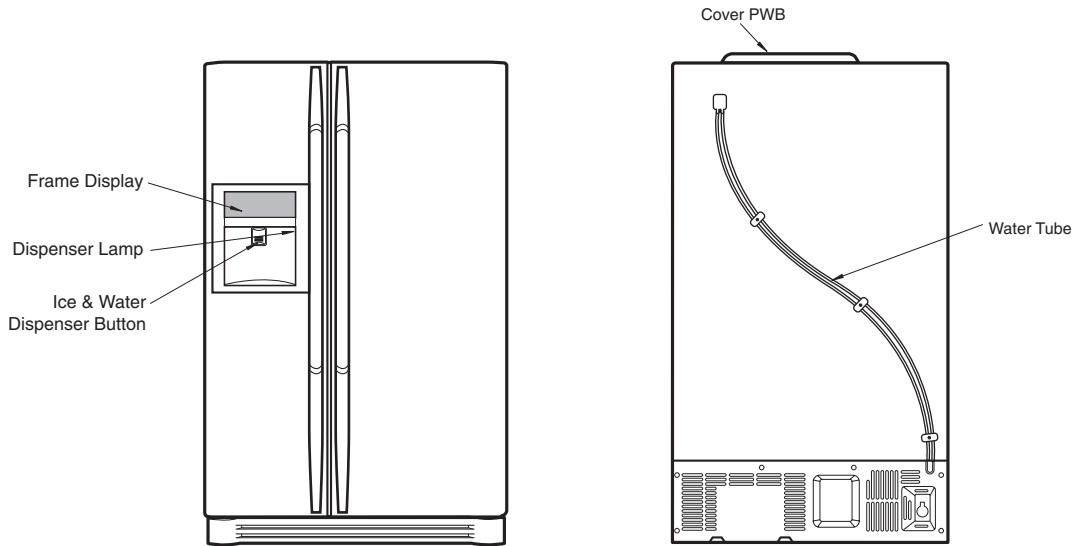

PARTS IDENTIFICATION

4. Ref No. : GR-P227/GR-P257 (EXTERNAL FILTER)

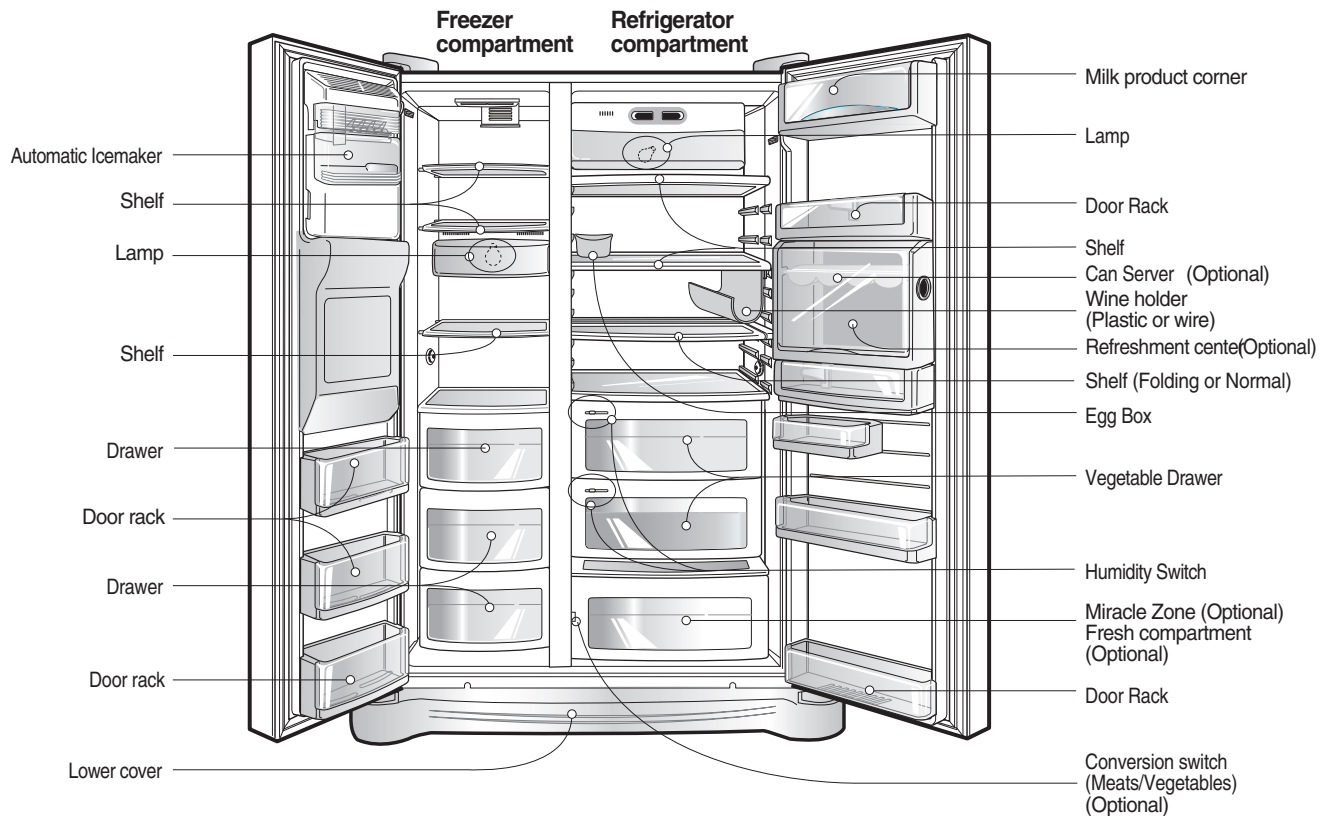
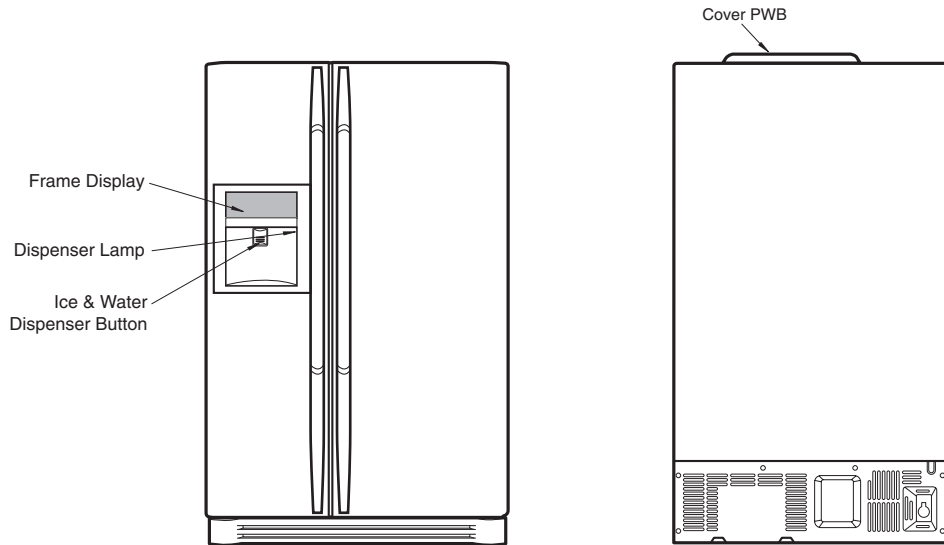

HOW TO INSTALL REFRIGERATOR

1. How to Adjust Door Height of Refrigerator

- Make the refrigerator level first. (If the refrigerator is not installed on the flat floor, the height of freezer and refrigerator door may not be the same.)

1. If the height of freezer door is lower than that of refrigerator compartment :

2. If the height of freezer door is higher than that of refrigerator compartment :

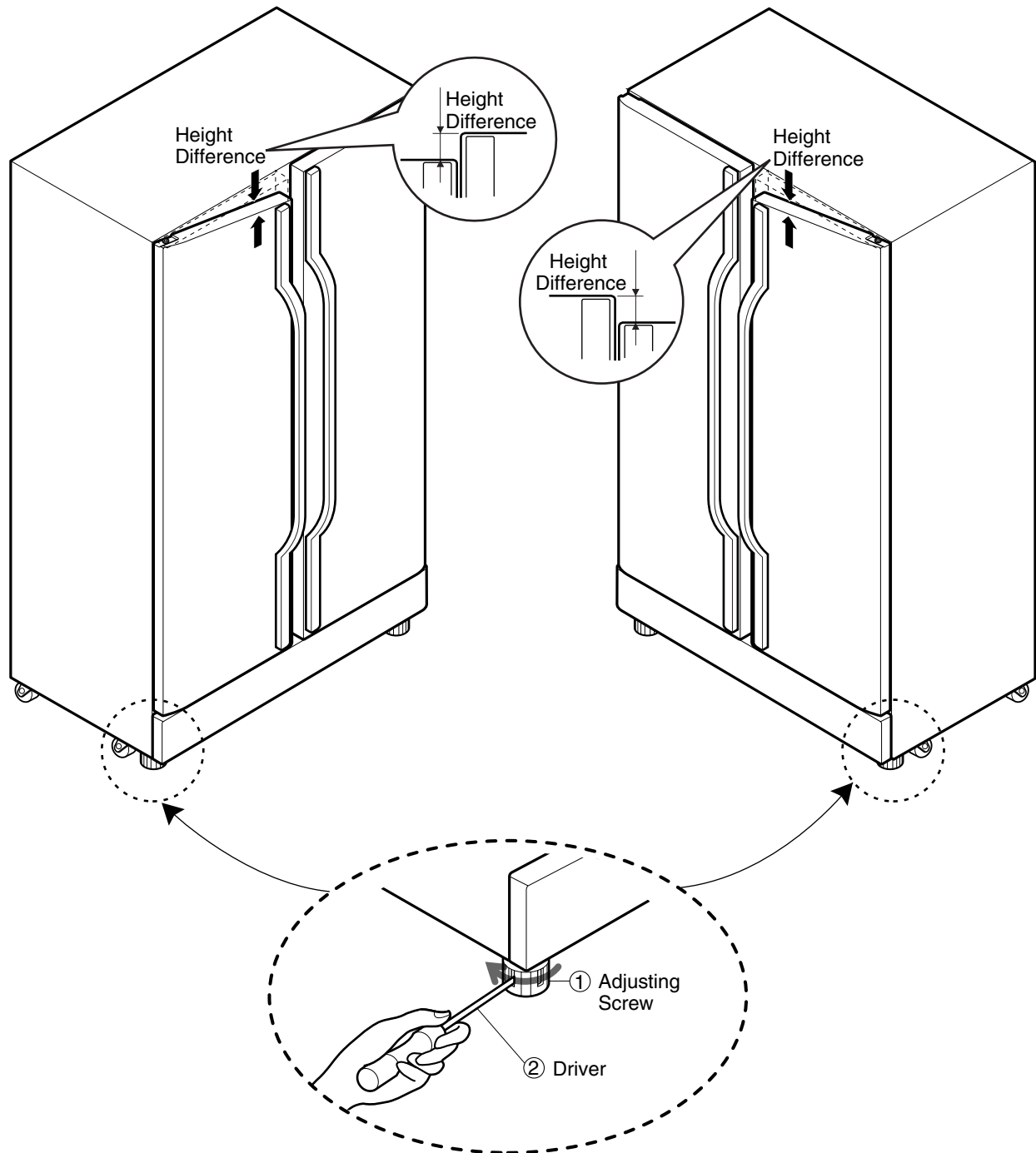

Insert a driver ② into the groove ① of adjusting screw and rotate driver in arrow direction (clockwise) until the refrigerator becomes horizontal.

Insert a driver ② into the groove ① of adjusting screw and rotate driver in arrow direction (clockwise) until the refrigerator becomes horizontal.

HOW TO INSTALL REFRIGERATOR

2. How to Install Water Pipe

■ Before Installation

1. The icemaker requires the water pressure of 1.5 - 8.5kgf/cm². (It is acceptable if city water fills a cup of 180cc with water for 3 seconds)
2. Install booster pump where the city water pressure is below 1.5kgf/cm² for normal operation of water and ice dispenser.
3. The total length of water pipe shall be less than 12m. Do not bend the pipe at right angle. If the length is more than 12m, there will be troubles on water supply due to water pressure drop.
4. Please install water pipe where there is no heat around.

2-1. When connecting directly to the water tap.

■ Please confirm the following installation parts.

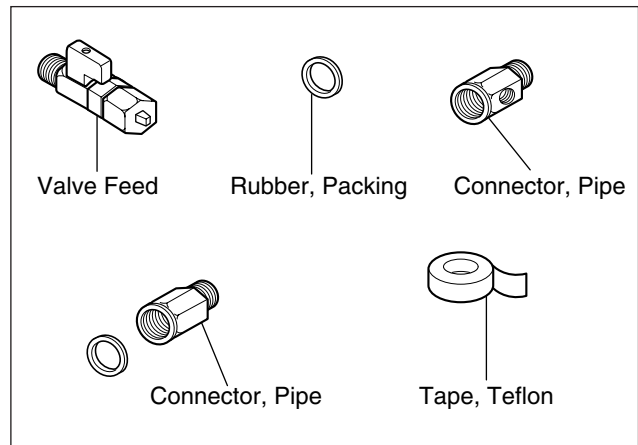

Class.	Shape and Spec.	Nomenclature	P/No	Remarks
Convertible Water Valve		Valve Feed	5221JA3001A	Common Use
Water Connector		Connector, (MECH) Pipe Conversion Connector(3/4") Balance Conector(3/4") Packing(ø24x3t)	4932JA3003A 6631JA3004A 6631JA3004B 3920JA3001B	No Holes
	Connector, (MECH) Pipe	4932JA3003B Conversion Connector(W25) Balance Conector(W25) Packing(ø23x3t)	6631JA3004C 6631JA3004D 3920JA3001A	No Holes
		Connector, (MECH) Pipe Conversion Connector(W28) Balance Conector(W28) Packing(ø26x3t)	4932JA3003C 6631JA3004E 6631JA3004F 3920JA3001C	No Holes
		Connector, (MECH) Pipe Conversion Connector(1/2") Balance Conector(1/2") Packing(ø19x3t)	4932JA3003D 6631JA3004G 6631JA3004H 3920JA3001D	No Holes

HOW TO INSTALL REFRIGERATOR

1. Connection of Pipe Connector A and B.

- 1) Turn off main valve of water pipe.
- 2) Disconnect water tap from piping by loosening nuts.
- 3) Connect pipe connector A and B to piping after sealing the pipe connector with sealing tapes.
- 4) Connect feed valve to pipe connector A.
- 5) If there is only one tap water pipe, connect pipe connector A only and install feed pipe.

- Caution :**
- Feed pipe should be connected to cold water line. If it is connected to hot water line, trouble may occur.
 - Please check rubber packing when connecting feed pipe.

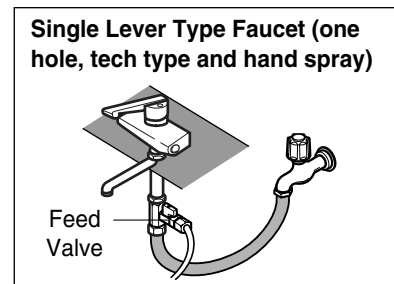
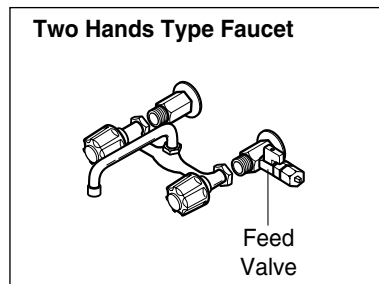
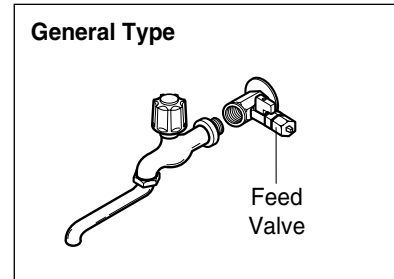
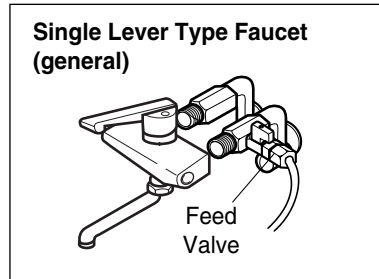
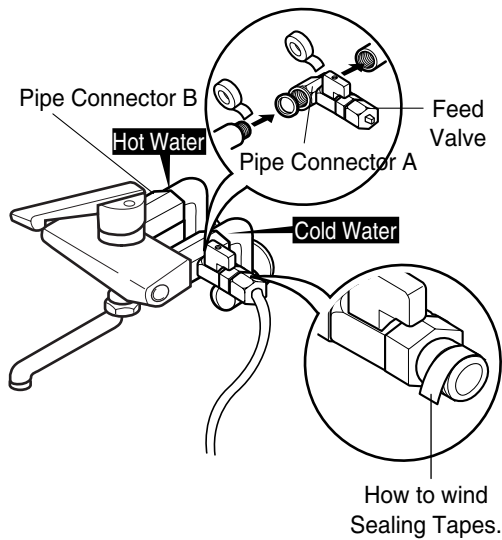

2. Water Supply

- 1) After the installation of feed water, plug the refrigerator to the earthed wall outlet, press the water dispenser button for 2 - 3 minutes, and confirm that the water comes out.
- 2) Check leakage at connecting part, then arrange water tube and locate the refrigerator at its regular place if there is no leaking.

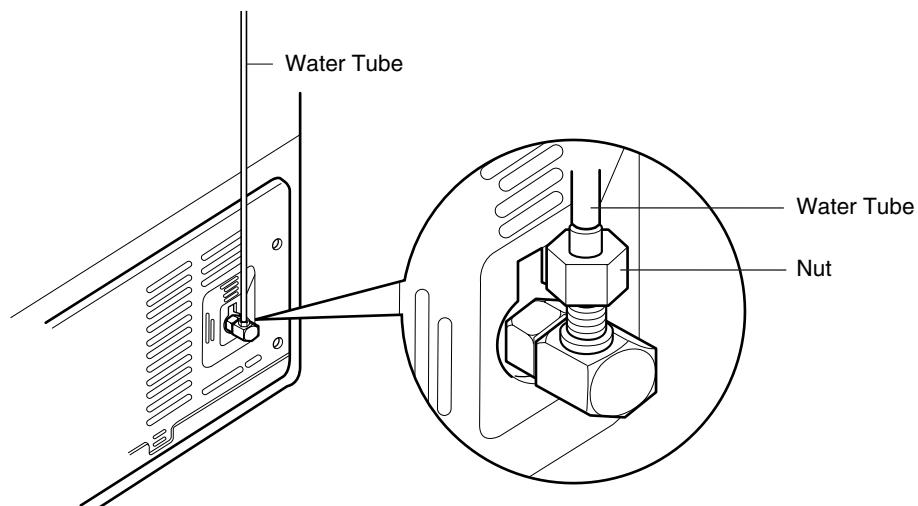

HOW TO INSTALL REFRIGERATOR

3. When customer uses bottled water.

*If customer wants to use bottled water, extra pump should be installed as shown below.

1. The pump system should not be on the floor (it may cause noise and vibration). Securely fasten the inlet and outlet nuts of pump.
2. If there is any leakage after installation, cut the water tube at right angle and reassemble.
3. When put the water tube end into the bottle, leave a clearance between bottle bottom and water tube end.
- 4 Check water coming out and any leakage.

Caution : • If feed tube is more than 4m, less water will come out due to pressure drops.

- Use standard feed tube to prevent leaking.

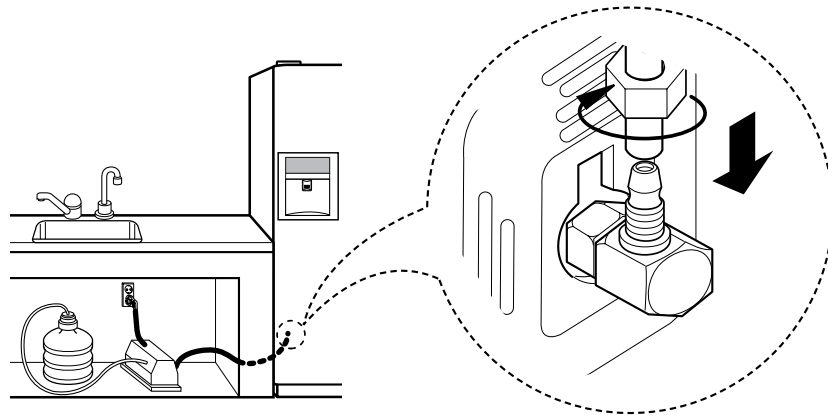

■ Outernal Filter

1. Filter Fixation

- 1) There are two types of filter. One is nut type and the other is connector type.
- 2) Connect feed tube to the filter outlet and water valve connecting tube.
- 3) Fix the filter at proper place around the sink where it is easy to replace the filter and to receive the cleaning water. Please consider the length of tube shall be less than 8m when locating filter.

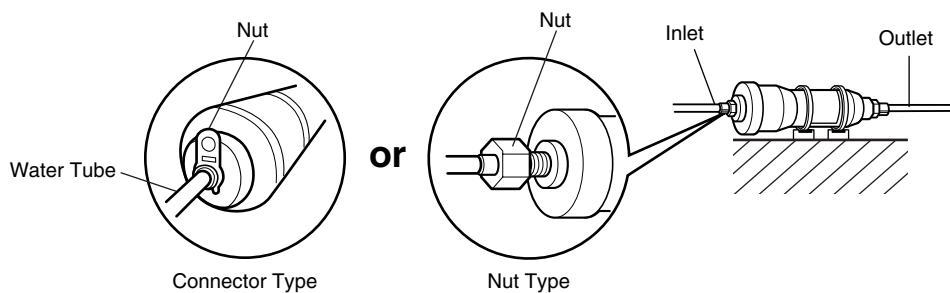

2. Filter Cleaning

- 1) Connect feed tube to the inlet of feed valve and filter.
- 2) Clean the main valve and feed valve with water for at least one minute until clean water comes out.

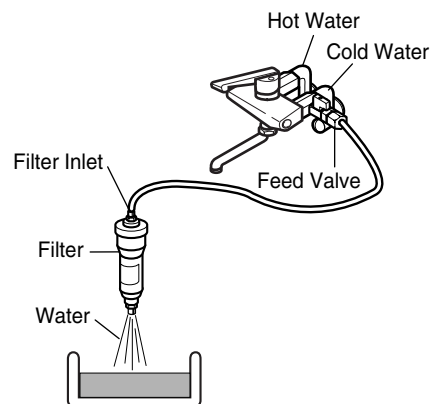

HOW TO INSTALL REFRIGERATOR

■ Install Water Filter (Applicable to some models only)

■ Before Installing water filter

1. Before installing the filter, take out the top shelf of the refrigerator after tilting it to the direction (①) and lifting it to the direction (②) and move it to the lower part.
2. Remove the lamp cover by pressing the protrusion under the cover and pulling the cover to the front.

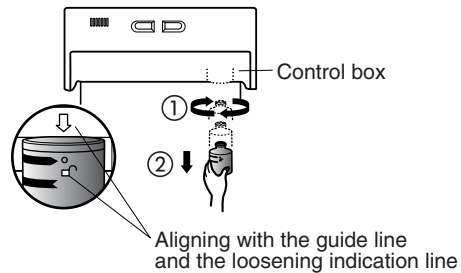
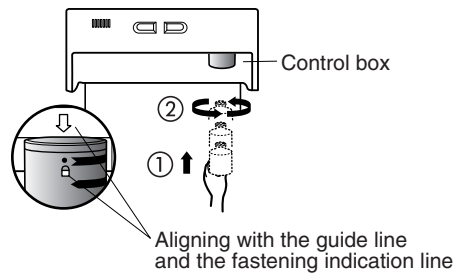
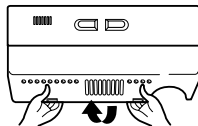
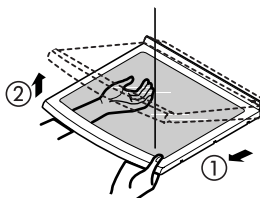

■ Installing water filter

1. Initial installation of water filter

Remove the filter substitute cap by turning it counterclockwise (①) by 90 degrees and pulling it down.

Note : Keep it safe to use it later when you do not use the filter.

Remove the red cap from the filter and attach the sticker. Insert the upper part of the filter (①) after aligning with the guideline marked on the control box, and fasten it by turning it clockwise by 90 degrees.

Note : Check that the guideline and the fastening indication line are aligned.

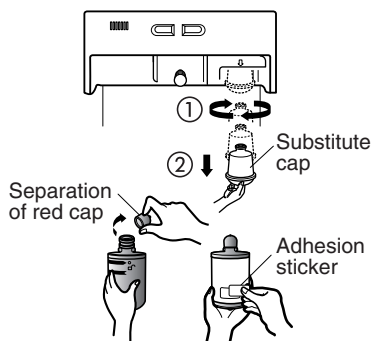

■ After installing water filter

Reassemble the lamp cover and the top shelf of the refrigerator. To place the top shelf of the refrigerator, raise the front part of the shelf a bit so that the hook of the shelf is fit into the groove.

In order to clean the water filter system, drain water for about 3 min.

Note : Then open the door of the refrigerator and check for water droppings on the shelf under the filter.

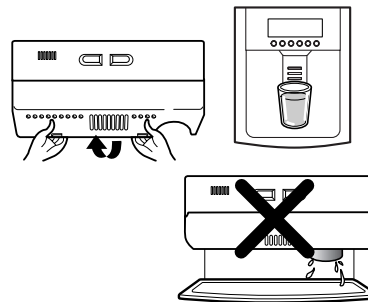

2. Replacement of water filter

While holding the lower part of the filter, turn it counterclockwise (①) by 90 degrees and pull it down.

Note : Check that the guideline and the loosening indication line are aligned.

HOW TO INSTALL REFRIGERATOR

3. How to Control the Amount of Water Supplied to Icemaker.

3-1. Confirm the amount of water supplied to the icemaker.

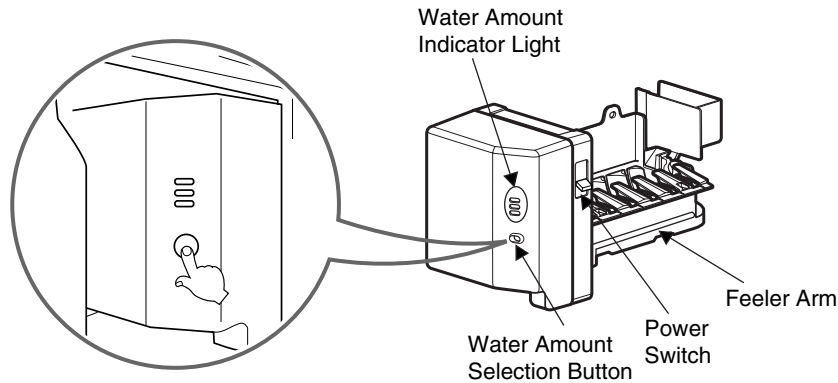

- 1) The automatic icemaker can automatically make 6 cubes at a time, 70~120 pieces per day. This quantity may vary by circumstance, including ambient temperature, door opening, freezer load. etc.
- 2) Icemaking stops when the ice bin is full.
- 3) If you don't want to use the automatic icemaker, turn the icemaker switch to OFF. If you want to use automatic icemaker again, change the switch to ON.
- 4) The water amount will vary depending on the water amount selection button. Setting, as well as the water pressure of the connected water line.

NOTE

- It is normal that a noise is produced when ice drops into the ice storage bin.

MICOM FUNCTION

1. Monitor Panel

1-1. GR-P227/GR-P257

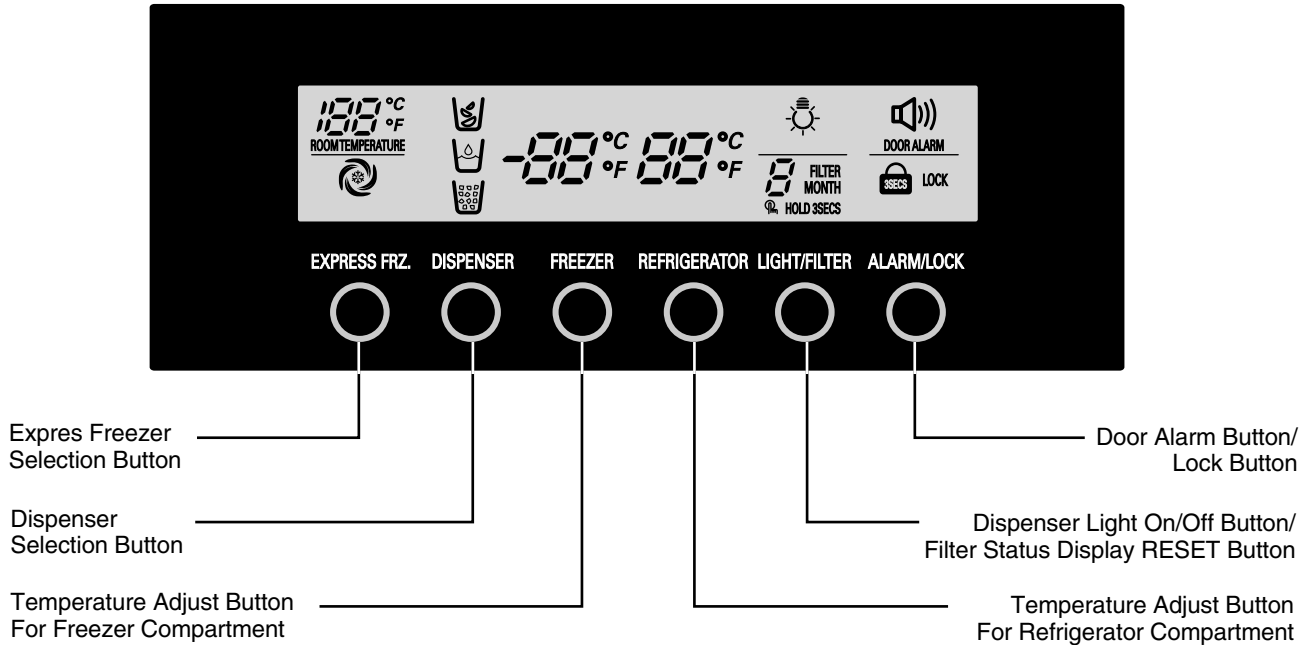

1-2. Display Second Function

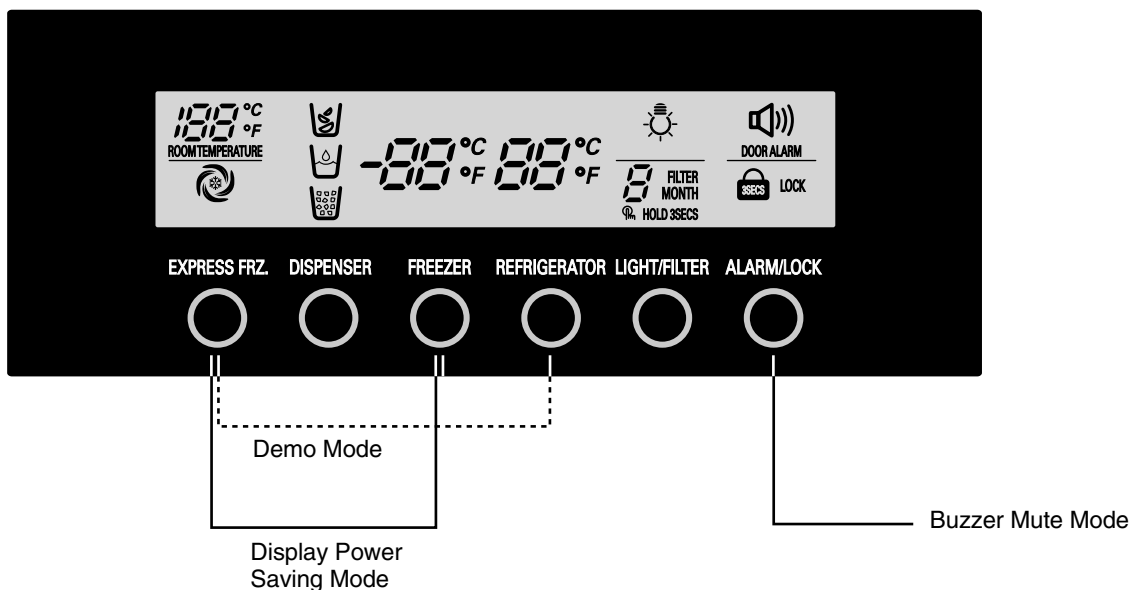

1. Door Alarm Buzzer Mute Mode

Press ALARM/LOCK to turn the buzzer on or off.

2. Display Power saving Mode

It places display in standby mode until door is opened.

Press FREEZER and EXPRESS FRZ. buttons simultaneously to turn all LEDs ON and then OFF with the recognition sound of Ding~ after 5 seconds. (Be sure not to press only one button to work.)

MICOM FUNCTION

Once the mode activates, the display is always OFF. Until door is opened or display button is pressed. When 20 seconds has elapsed after closing door or pressing button, the display turns OFF. To deactivate this mode is same as the activation methods. The mode inactivates when resetting the power.

3. Exhibition Mode

Demo mode is available for displaying the refrigerator in a sales setting or similar condition.

It allows the display, dispenser, lights, and fan to operate without running the compressor.

To enter the DEMO mode, press and hold the REFRIGERATOR and EXPRESS FRZ. buttons simultaneously for 5 seconds until the Ding~ sounds.

To exit the DEMO mode and return to normal operation, press and hold the REFRIGERATOR and EXPRESS FRZ. buttons simultaneously for 5 seconds until the Ding~ sounds again.

The refrigerator will default to the NORMAL mode (DEMO mode OFF) if the power fails.

2. Description of Function

2-1-1. Function of Temperature Selection

Division	Power Initially On	1st Press	2st Press	3th Press	4th Press
Temperature Control	Medium	Medium Max	Max	Min	Medium Min
Freezer Control	-19 °C	-22 °C	-23 °C	-15 °C	-17 °C
Refrigeration Control	3 °C	2 °C	0°C	6 °C	4 °C

* The temperature can vary ± 3 °C depending on the load condition.

* Whenever pressing button, setting is repeated in the order of (Medium) → (Medium Max) → (Max) → (Min) → (Medium Min).

- The actual inner temperature varies depending on the food status, as the indicated setting temperature is a target temperature, not actual temperature within refrigerator.
- Refrigeration function is weak in the initial time. Please adjust temperature as above after using refrigerator for minimum 2~3 days.

MICOM FUNCTION

2-1-2. LCD Back Light Control

1. In order to easily view display status on the LCD, LCD Back Light is turned on for a minute in application of initial power, for a minute in button manipulation and for a minute after closing time from opening time of door.
2. If pressing any display button once with the backlight turned off, buzzer rings and button function is not performed but only backlight is turned on (If pressing the first button with the back light turned off, only back light ON function is performed).
3. If pressing the special freezing button and the freezing temperature adjustment button for more than a second, the back light is turned on and all the graphics of LCD are turned on. If releasing the button, the LCD graphic is displayed in the previous status and the back light is turned off (check LCD graphic and back light ON/OFF status).

2-1-3. Outside temperature display function

1. Outside temperature sensor at the left U of refrigerator senses ambient temperature and displays the outside temperature in the left side of "Outside temperature" text on the LCD of the display part.
2. Ambient temperature is displayed up to -9°C ~ 49°C and displayed as "Lo" for less than -10°C and as "HI" for more than 50°C. If the ambient temperature sensor fails, it is displayed as "Er".
3. Since display temperature of outside temperature is temperature sensed by the ambient sensor in the hinge U of the freezing room, it may differ from the outside temperature display of other household electrical appliances.

2-1-4. Lock function (display button lock)

1. In power application of refrigerator, the **LOCK** text is turned off at the right side of lock graphic of display with the lock release status.
2. If desiring to lock the display the dispenser and control panel, push on the LOCK button more than 3 seconds. LOCK is turned on at the right side of lock graphic of display with lock status.
3. The buzzer sound and control panel and dispenser function is not performed even if pressing display button other than lock key in the lock status.
4. If desiring to release the lock status and pressing the lock button more than 3 seconds. LOCK text is turned off at the right side of lock graphic of display with the lock release status.

2-1-5. Filter condition display function

1. There is a replacement indicator light for the water filter cartridge on the dispenser.
2. Water filter needs replacement once six months.
3. Water filter light and FILTER RESET HOLD 3SECS text turn on to tell you need to replace the filter soon.
4. After replacing the filter, press and hold the lock button more than 3seconds.
Then water filter light and FILTER RESET HOLD 3SECS text turn off with reset status.

LIGHT/FILTER

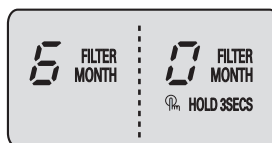

MICOM FUNCTION

2-2. Dispenser use selection

You can select water or ice.

- * Please select water, slice ice and square ice by pressing  button as you desire.
- * Please press the push button lightly by catching and pushing in cup.
 - The border line is indicated for the selected function.
 - “Tak!” sounds if 5 seconds pass after ice comes out.
 - It is sound that the outlet of ice is closed.

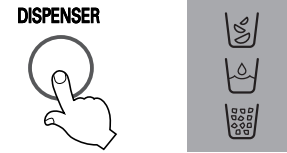

REFERENCE : Please wait for 2-3 seconds in order to take final ice slices or drops of water when taking out cup from the pressing switches after taking ice or water.

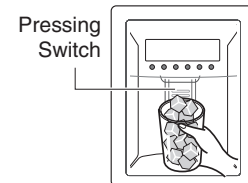

2-3. Automatic ice maker

- The automatic ice maker can automatically make 8 pieces of ice cube at a time, 80 pieces a day. But these quantities may be varied according to various conditions including how many times the refrigerator door opens and closes.
- Ice making stops when the ice bin is full.
- If you don't want to use automatic ice-maker, change the ice-maker switch to ON-OFF. If you want to use automatic ice-maker again, change the switch to OFF-ON.

NOTE : It is normal that a noise is produced when ice made is dropped into the ice bin.

2-4. When ice maker does not operate smoothly

Ice is lumped together

- When ice is lumped together, take the ice lumps out of the ice bin, break them into small pieces, and then place them into the ice bin again.
- When the ice maker produces too small or lumped together ice, the amount of water supplied to the ice maker need to adjusted. Contact the service center.
- * If ice is not used frequently, it may lump together.

Power failure

- Ice may drop into the freezer compartment. Take the ice bin out and discard all the ice then dry it and place it back. After the machine is powered again, crushed ice will be automatically selected.

The unit is newly installed

- It takes about 12 hours for a newly installed refrigerator to make ice in the freezer compartment.

2-5. Express Freezer

Please select this function for prompt freezer.

- “On” or “Off” is repeated whenever pressing  button.
- The arrow mark graphic remains at the On status after flickering 4 times when selecting Special Refrigeration “On”.
- Super freezer function automatically turns off if a fixed time passes.

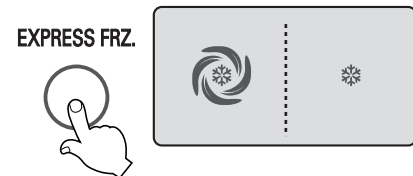

2-6. Lock

This button stops operation of different button.

- Locking or Release is repeated whenever pressing the .
- Pressing the other button when selecting ‘ALARM/LOCK’, the button does not operate.

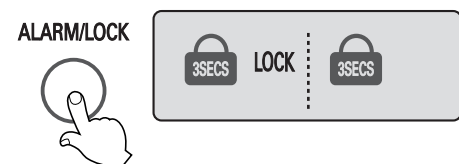

MICOM FUNCTION

2-7. Super freezing

1. EXPRESS FRZ freezing is a function to increase the cooling speed of the freezer compartment by running both the compressor and the fan simultaneously.
2. EXPRESS FRZ is cancelled and the refrigerator returns to its default setting in the event of a power interruption.
3. Selecting EXPRESS FRZ changes only the speed of the cooling without affecting the set temperature.
4. The temperature can be adjusted even when EXPRESS FRZ has been selected and is in progress.
5. The freezer operates at whatever temperature was set at the time EXPRESS FRZ was selected.
6. If you select EXPRESS FRZ, the compressor and fan will run until it is deselected or the cycle time has elapsed.
(3 hours : compressor and fan run / 3 ~ 24 hours : COLDEST operation)
7. If a defrost cycle occurs while an EXPRESS FRZ is already running, EXPRESS FRZ runs for its remaining cycle time after the defrost cycle is completed. If the defrost cycle takes longer than 30 minutes, EXPRESS FRZ will run for only 2 hours at the end of the defrost cycle.
8. If you press EXPRESS FRZ during a defrost cycle, the EXPRESS FRZ indicator (LCD or LED, depending upon the model) will illuminate but the compressor will not operate until the defrost cycle is complete.
9. If you press EXPRESS FRZ within 7 minutes of compressor cut-off, the compressor will not operate until the 7-minute delay has passed.
10. The freezer fan motor runs at high speed during the EXPRESS FRZ cycle.

2-8. *Miracle Zone function

1. Miracle Zone is located at the bottom room of R-room and maintains optimum temperature depending on foods through selection of desired foods kept in the Miracle Zone from vegetables to meat with a display.
Set temperature in the Miracle Zone by using a separate selection button at the right side of the Miracle Zone. Initial notch is in "veg." status in application of power. Whenever pressing buttons, notch changes while LED is displayed in the order of "veg. → cheeze → meat → veg."
Provided that selected notch LED turns off if opening doors of the R-room and it turns off if closing doors of R-room.
2. Temperature of the miracle zone is controlled with a stamping damper at the left side of the miracle zone and controlled with a miracle zone at the rear side of miracle zone.
3. Change of the notch by temperature control S/W at the miracle zone is controlled after 10 seconds have passed after selecting final notches.
4. Miracle zone damper is forcedly closed during test mode or defrost mode.

2-9. Control of variable type of freezing room fan

Miracle Zone NOTCH	meat	cheeze	veg.
Setting Indication	-1°C	2°C	4°C

1. To increase cooling speed and load response speed, MICOM variably controls freezing room fan motor at the high speed of RPM and standard RPM.
2. MICOM only operates in the input of initial power or super freezing operation or load response operation for the high speed of RPM and operates in the standard RPM in other general operation.
3. If opening doors of freezing / cold storage room or home bar while fan motor in the freezing room operates, the freezing room fan motor normally operates (If being operated in the high speed of RPM, it converts operation to the standard RPM). However, if opening doors of freezing room or home bar, the freezing room fan motor stops.
4. As for monitoring of BLDC fan motor error in the freezing room, MICOM immediately stops the fan motor by determining that the BLDC fan motor is locked or poor if there would be position signal for more than 115 seconds at the BLDC motor. Then it displays failure (refer to failure diagnosis function table) at the display part of refrigerator, the BLDC motor doesn't operate more. If you want to operate the BLDC motor, turn off and on power resource.

MICOM FUNCTION

2-10. Control of M/C room fan motor

1. The M/C room fan motor performs ON/OFF control by linking with the COMP.
2. It controls at the single RPM without varying RPM.
3. Failure sensing method is same as in fan motor of freezing fan motor (refer to failure diagnosis function table for failure display).

2-11. Door opening alarm

1. Buzzer generates alarm sound if doors are not closed even when more than a minute consecutively has passed with doors of freezing / cold storage room or home bar opened.
2. Buzzer rings three times in the interval of 0.5 second after the first one-minute has passed after doors are opened and then repeats three times of On/Off alarm in the cycle of every 30 seconds.
3. If all the doors of freezing / cold storage room or home bar are closed during door open alarm, alarm is immediately released.

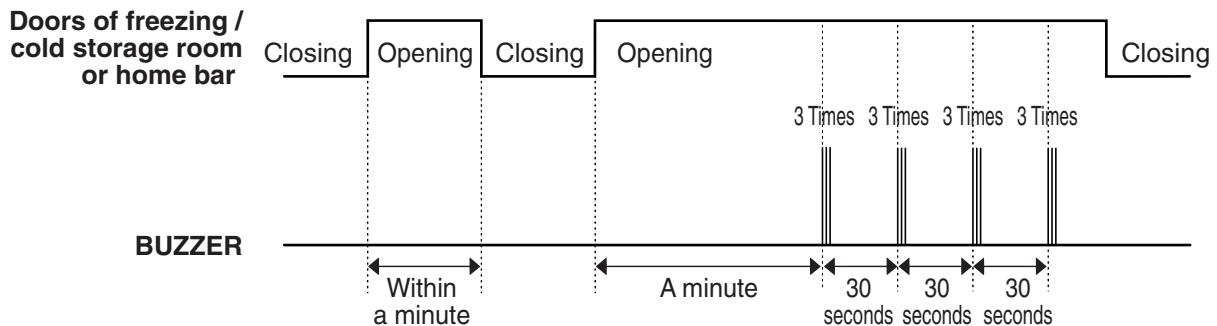

2-12. Ringing of button selection buzzer

1. If pressing the front display button, "Ding ~ " sound rings.

2-13. Ringing of compulsory operation, compulsory frost removal buzzer

1. If pressing the test button in the main PCB, "Phi ~ " sound rings.
2. In selecting compulsory operation, alarm sound is repeated and completed in the cycle of On for 0.2 second and Off for 1.8 second three times.
3. In selecting compulsory frost removal, alarm sound is repeated and completed in the cycle of On for 0.2 second , Off for 0.2 second, On for 0.2 second and Off for 1.4 second three times.

2-14. Frost removal function

1. Frost removal is performed whenever total operation time of compressor becomes 7 ~ 7.5 hour.
2. In providing initial power (or returning power failure), frost removal starts whenever total operation time of compressor becomes 4 ~ 4.5 hour.
3. Frost removal is completed if temperature of a frost removal sensor becomes more than 5°C after starting frost removal.
Poor frost removal is not displaced if it does not arrive at 5°C even if two hours have passed after starting frost removal.
4. No removal is done if frost removal sensor becomes poor (snapping or short-circuit).

MICOM FUNCTION

2-15. Sequential operation of built-in product

Built-in products such as compressor, frost removal heater, freezing room fan, Cooling Fan and step motor damper are sequentially operated as follows for preventing noise and part damage occurred due to simultaneous operation of a lot of parts in applying initial power and completing test.

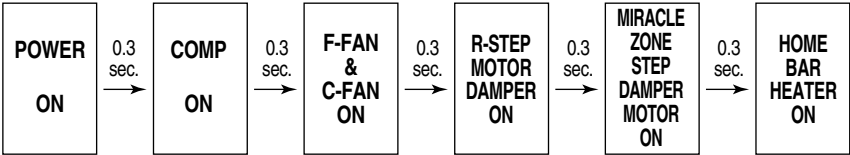
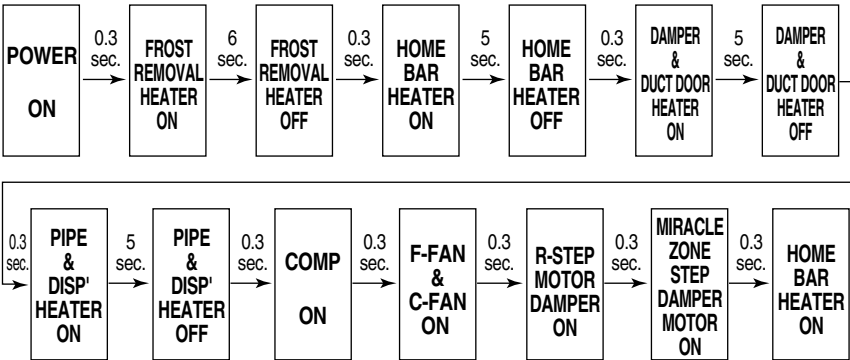
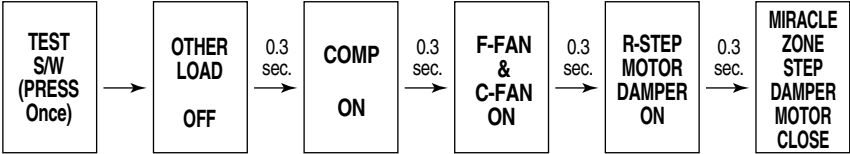
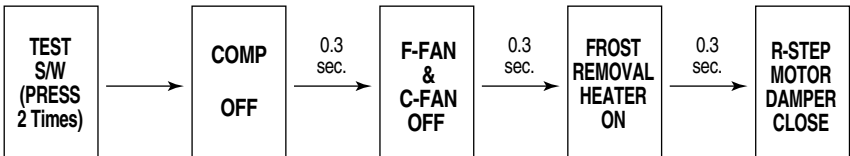
Function	Load Operation Sequence	Remark
In applying Initial power	<p>When temperature of a frost removal sensor becomes more than 45°C (In purchase, movement)</p> 	<p>If error occurs during operation, initial operation is not done.</p> <p>■ Sequence of load operation when closing F-room and R-room.</p>
	<p>When temperature of a frost removal sensor becomes less than 45°C (In power failure, service)</p> 	
TEST MODE	<p>Test mode 1 (Compulsory function)</p> 	<p>If pressing switch once more in the test mode 2 or temperature of a frost removal sensor is more than 5°C, it immediately returns to the test mode for initial operation (COMP operates after 7 minutes).</p>
	<p>Test mode 2 (Compulsory frost removal)</p> 	

MICOM FUNCTION

2-16. Failure Diagnosis Function

1. Failure diagnosis function is function to facilitate service when nonconforming matters affecting performance of product during use of product.
2. In occurrence of failure, pressing the function adjustment button does not perform function.
3. If nonconforming matters occurred are released during display of failure code, MICOM returns to the original state (Reset).
4. Failure code is displayed on the display part of setting temperature for the freezing room and the display part of setting temperature for the cold storage room of LCD, which are placed at the display part of a refrigerator. All the LCD graphics other than a failure code are turned off.

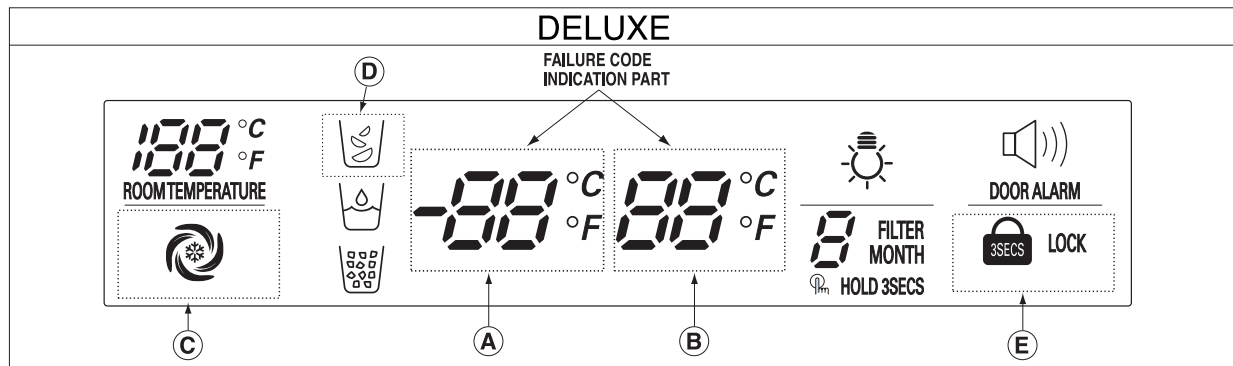

○ : PROPER OPERATION

NO	ITEM	FAILURE CODE INDICATION PART		CONTENTS OF FAILURE	PRODUCT OPERATION STATUS IN FAILURE				
		FREEZER ROOM NOTCH TEMPERATURE DISPLAY	REFRIGERATOR ROOM NOTCH TEMPERATURE DISPLAY		COMPRESSOR	FREEZING BLDC MOTOR	COOLING BLDC MOTOR	DEFROST HEATER	STEPPING MOTOR DAMPTER
1	ABNORMAL FREEZER SENSOR	Er	FS	FREEZER SENSOR SHORT CIRCUIT	ON FOR 15 MINUTES / OFF FOR 15 MINUTES	STANDARD RPM	○	○	○
2	ABNORMAL REFRIGERATOR SENSOR1(R1) (UPPER PART IN THE REFRIGERATOR COMPARTMENT)	Er	rS	REFRIGERATOR SENSOR1 SHORT CIRCUIT	○	STANDARD RPM	○	○	FULL OPENING FOR 10 MINUTES/ FULL CLOSING FOR 15 MINUTES
3	ABNORMAL REFRIGERATOR SENSOR2(R2) (LOWER PART IN THE REFRIGERATOR COMPARTMENT)	NORMAL DISPLAY (NOTE2)		REFRIGERATOR SENSOR2 SHORT CIRCUIT	○	STANDARD RPM	○	○	○
4	ABNORMAL DEFROST SENSOR	Er	dS	ABNORMAL SHORT CIRCUIT	○	STANDARD RPM	○	NO DEFROST	○
5	FAILED DEFROSTING	Er	dH	DEFROST HEATER, TEMPERATURE FUSE SHORT CIRCUIT, UNPLUGGED CONNECTOR(INDICATED 4 HOUR LATER AFTER TROUBLE)	○	STANDARD RPM	○	○	○
6	ABNORMAL FREEZING BLDC MOTOR	Er	FF	MOTOR DEFECT, HOOKED OF LEAD WIRE TO FAN, CONTACT OF STRUCTURES WITH FAN, SHORT OR OPEN OF LEAD WIRE(THERE IS NO SIGNAL OF BLDC MOTOR MORE THAN 115 SECONDS IN OPERATION OF FAN MOTOR)	○	OFF	○	○	○
7	ABNORMAL COOLING BLDC MOTOR	Er	CF	NO SIGNAL OF BLDC MOTOR MORE THAN 115 SECONDS IN OPERATION OF FAN MOTOR)	○	STANDARD RPM	OFF	○	○
8	ABNORMAL COMMUNICATION	Er	CO	SHORT OR OPEN OF LEAD WIRE CONNECTING BETWEEN MAIN PCB AND DISPLAY PCB, TRANSMISSION TR AND RECEIVING PART	○	STANDARD RPM	○	○	○
9	ABNORMAL AMBIENT SENSOR	NORMAL DISPLAY (NOTE1)		AMBIENT SENSOR SHORT CIRCUIT	○	○	○	○	○
10	ABNORMAL WATER-TANK SENSOR	NORMAL DISPLAY (NOTE2)		WATER-TANK SENSOR SHORT CIRCUIT	○	○	○	○	○
11	ABNORMAL MAGIC ROOM SENSOR	NORMAL DISPLAY (NOTE2)		MAGIC ROOM SENSOR SHORT CIRCUIT	○	○	○	○	○

* All LCDs turn off other than freezer room notch temperature display and refrigerator room notch temperature display(failure code indication part) in case of indicating failure modes(except for Note1, Note2).

MICOM FUNCTION

* ALL DISPLAY PARTS TURN OFF OTHER THAN FREEZER ROOM NOTCH TEMPERATURE DISPLAY AND REFRIGERATOR ROOM NOTCH TEMPERATURE DISPLAY (FAILURE CODE INDICATION PART) IN CASE OF INDICATING FAILURE MODES (EXCEPT FOR NOTE1, NOTE2)

NOTE1) FREEZER ROOM NOTCH TEMPERATURE DISPLAY AND REFRIGERATOR ROOM NOTCH TEMPERATURE DISPLAY (FAILURE CODE INDICATION PART) ARE NORMALLY INDICATED IN ABNORMAL AMBIENT SENSOR, AND "E" INDICATED ON THE AMBIENT TEMPERATURE DISPLAY (EXCEPT FOR THE AMBIENT TEMPERATURE DISPLAY, OTHER DISPLAY PARTS ARE INDICATED NORMALLY)

NOTE 2) R2-SENSOR, WATER-TANK SENSOR AND MAGIC ROOM SENSOR IS NOT INDICATED ON THE FAILURE INDICATING PART BUT INDICATED IN CHECKING ALL DISPLAY PARTS (WHEN PRESSING FOR MORE THAN THE BUTTON OF FREEZING TEMPERATURE AND QUICK FREEZING BUTTON FOR MORE THAN 1 SECOND).

R2-SENSOR(MIDDLE ROOM)	N O R M A L : DISPLAY PART GRAPHIC ON THE (C) PART TURNS ON	THE OTHER DISPLAY GRAPHICS TURN ON
	A B N O R M A L : DISPLAY PART GRAPHIC ON THE (C) PART TURNS OFF	
WATER-TANK SENSOR	N O R M A L : DISPLAY PART GRAPHIC ON THE (D) PART TURNS ON	
	A B N O R M A L : DISPLAY PART GRAPHIC ON THE (D) PART TURNS OFF	
MAGIC ROOM SENSOR	N O R M A L : DISPLAY PART GRAPHIC ON THE (E) PART TURNS ON	
	A B N O R M A L : DISPLAY PART GRAPHIC ON THE (E) PART TURNS OFF	

2-17. Test Function

1. The purpose of test function is to check function of the PWB and product and to search for the failure part at the failure status.
2. Test button is placed on the main PCB of refrigerator (test switch), and the test mode will be finished after maximum 2 hours irrespective of test mode and then is reset to the normal status.
3. Function adjustment button is not perceived during performance of test mode.
4. In finishing test mode, always pull the power cord out and then plug-in it again for the normal state.
5. If nonconforming contents such as sensor failure are found during performance of test mode, release the test mode and display the failure code.
6. Even if pressing the test button during failure code display, test mode will not be performed.

Mode	Operation	Contents	Remarks
Test 1	Press test button once (strong cold mode)	<ol style="list-style-type: none"> 1. Continuous operation of compressor 2. Continuous operation of freezing bldc motor (high-speed RPM) and cooling bldc motor 3. Defrost heater turns off 4. Stepping motor damper is completely opened (open of baffle) 5. Miracle zone stepping motor damper is completely closed. 6. All display LCD graphics turns on. 	Freezing fan turns off in door opening
Test 2	Press test button once at the test mode 1 status (forced defrost mode)	<ol style="list-style-type: none"> 1. Compressor OFF 2. Freezing bldc motor and cooling bldc motor turn off 3. Defrost heater turns on 4. Stepping motor damper is completely closed (closing of baffle) 5. Miracle zone stepping motor damper is completely closed. 6. All display LCD graphics turns off (only LCD turns on for(A) "MIDIUM" status, (B) "MIDIUM" status) 	Return to the normal mode when the defrost sensor is above +5°C
Normal Status	Press test button once at the test mode 2 status	Return to the initial status.	Compressor will operate after delay for 7 minutes

MICOM FUNCTION

* LCD check function: If simultaneously pressing super freezer button and freezing temperature adjustment button for a second, a back light is turned on and all display LCD graphics on. If releasing the button, the LCD graphic displays the previous status, the back light is turned off (LCD graphic and back light ON/OFF check).

<TEST MODE 1 STATUS LCD>

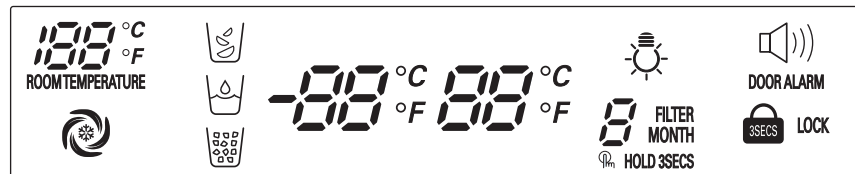

<TEST MODE 2 STATUS LCD>



2-18. Function of dispenser and water dispenser built-in

1. This is function allowing ice and water to come outside without opening door.
2. If pressing the dispenser switch (rubber button) after selecting ice (cube ice, crushed ice) or water, ice and water equivalent to each come out. However, the duct doors are opened by electrical solenoid valve (Duct Door Solenoid) if pressing the press switch in case of selecting ICE. If pressing the dispenser press switch and then detaching the hands, the duct door is closed after it is opened for 5 seconds.
3. Function allowing ice and water to come stops if freezing room doors are opened.
4. If there is no Off signal even when 3 minutes have passed while pressing the dispenser press switch after selecting ice (cube ice, crushed ice) or water, geared motor and solenoid (Cube, Water) is automatically turned off. However, the solenoid (duct door) is stop 5 seconds after Off (to prevent short-circuit of a coil due to overheat of solenoid).
5. Dispenser Lamp On/Off function
Lamp on the dispenser part is turned on if pressing the dispenser press switch after selecting ice (cube ice, crushed ice) or water. If detaching the hands, it is turned off.
6. Selection function of water/crushed/ cube ice
 - 1) This is function to allow selection of water/crushed/ cube ice function depending on user's selection. Display and selection is done if pressing the dispenser selection button.
 - 2) In the initial Power On, cube ice is automatically selected.
 - 3) In selecting cube ice, geared motor is operated so that crushed ice can be supplied outside if pressing the press switch when ice is formed in the ice storage container (Bank, Ice).
 - 4) In selecting cube ice, geared motor is operated so that cube ice can be supplied outside if pressing the press switch when ice is formed in the ice storage container (Bank, Ice).
7. Water dispenser function
 - 1) LCD is displayed for selection if user selects water at the function adjustment part.
 - 2) Water dispenser function is a type directly connected to a water pipe. The water solenoid valve built-in at the right side of the M/C room is opened so that water can be supplied if selecting Water from the function adjustment part and then pressing the press switch.

EXPLANATION FOR MICOM CIRCUIT

1. Explanation for PWB circuit

1-1. Power circuit

The power circuit includes a Switched Mode Power Supply (SMPS). It consists of a rectifier (BD1 and CE1) converting AC to DC, a switch (IC2) switching the DC voltage, a transformer, and a feedback circuit (IC3 and IC4).

Caution : Since high voltage (310 Vdc) is maintained at the power terminal, wait at least 3 minutes after unplugging the appliance to check the voltages to allow the current to dissipate.

Voltage of every part is as follows:

Part	VA1	CE1	CE2	CE3	CE4	CE5
Voltage	230 Vac	310 Vdc	16 Vdc	12 Vdc	16 Vdc	5 Vdc

(1) GR-P227/L227

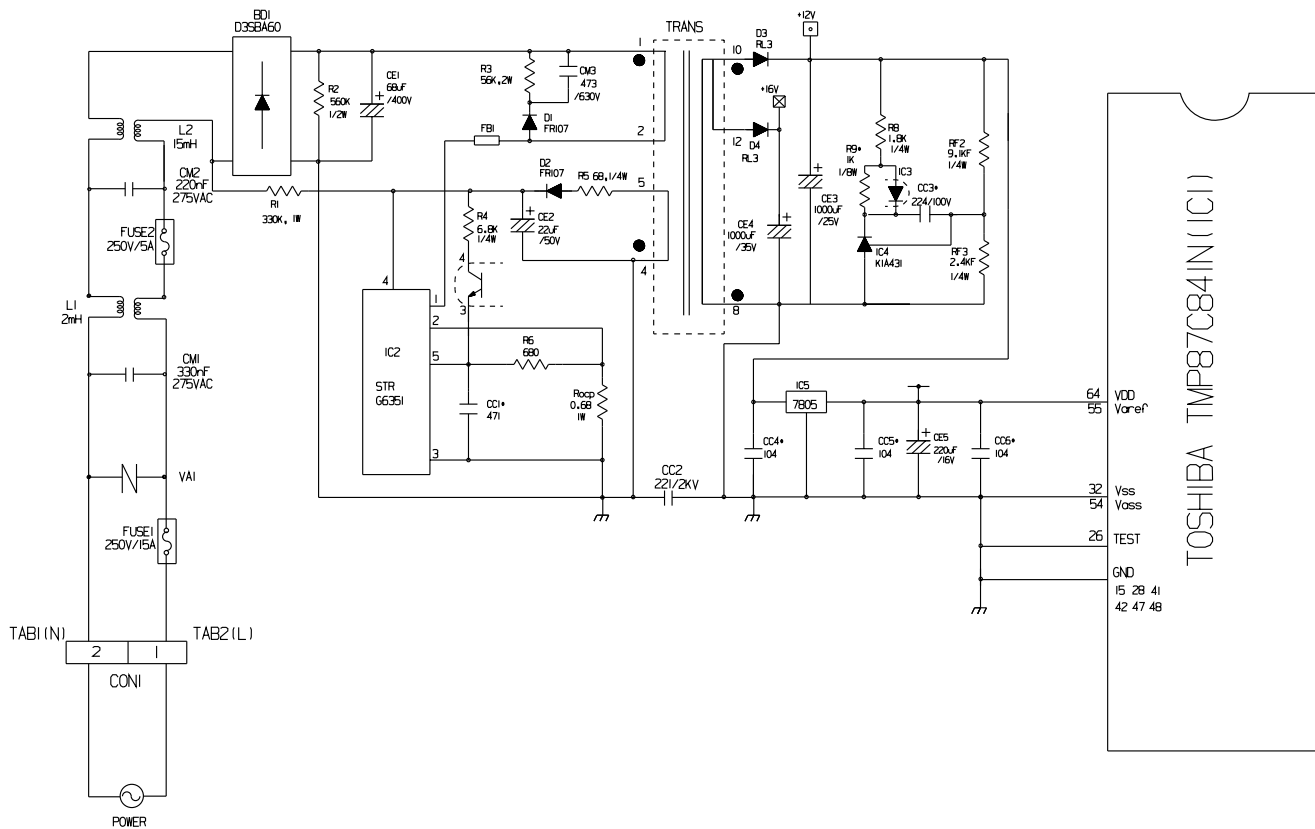

EXPLANATION FOR MICOM CIRCUIT

1-2. Oscillation circuit

The oscillation circuit generates a basic clock signal for synchronization and time calculation related to the transmission of data and calculations made by the MICOM (IC1). The oscillator (OSC1) must always be replaced with an exact replacement part. If this specification is changed, the change will affect the time calculations of the MICOM and it might not work at all.

(1) GR-P227/L227/P257/L257

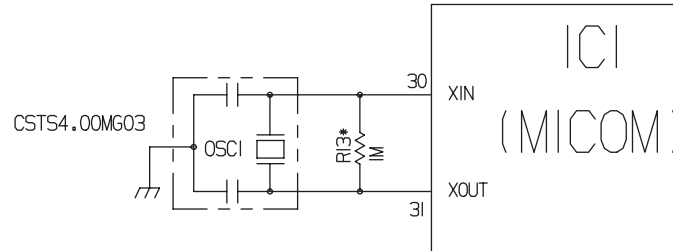

1-3. Reset circuit

The RESET circuit allows various parts of the MICOM, such as RAM, defrosting, etc., to be restarted from the initial state when power is interrupted or restored. A LOW signal applied to the reset terminal for 10 ms causes the MICOM to reset itself. During normal operation, the voltage at the reset terminal is 5 Vdc. If the reset fails, the MICOM will not operate.

(1) GR-P227/L227/P257/L257

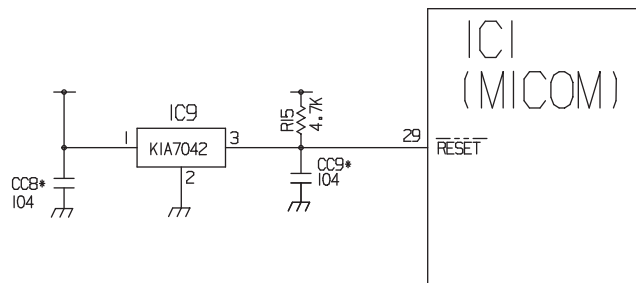

EXPLANATION FOR MICOM CIRCUIT

1-4. Load/dispenser operation, door opening circuit

1. LOAD DRIVING CIRCUIT

- * The fan operates at the regular speed even if the door of the refrigerator or freezer is opened. When the doors are closed, the fan reverts to its original speed.
- * (A), (B), (C), and (D) of door switch for the freezer or refrigerator are connected to the door open sensing circuit in parallel toward both ends of switch to determine door open at MICOM.
- * In the TEST mode, the fan will stop if any door is opened. It will resume operation when the door is closed.

Type of Load	Compressor	Defrost Heater	AC Converting Relay	Refrigerator LAMP	Dispenser Heater
Measuring part (IC6)	IC6-16	IC6-13	IC6-12	IC6-15	IC6-14
Status	ON	Within 1 V			
	OFF	12 V			

(1) GR-P227/L227/P257/L257

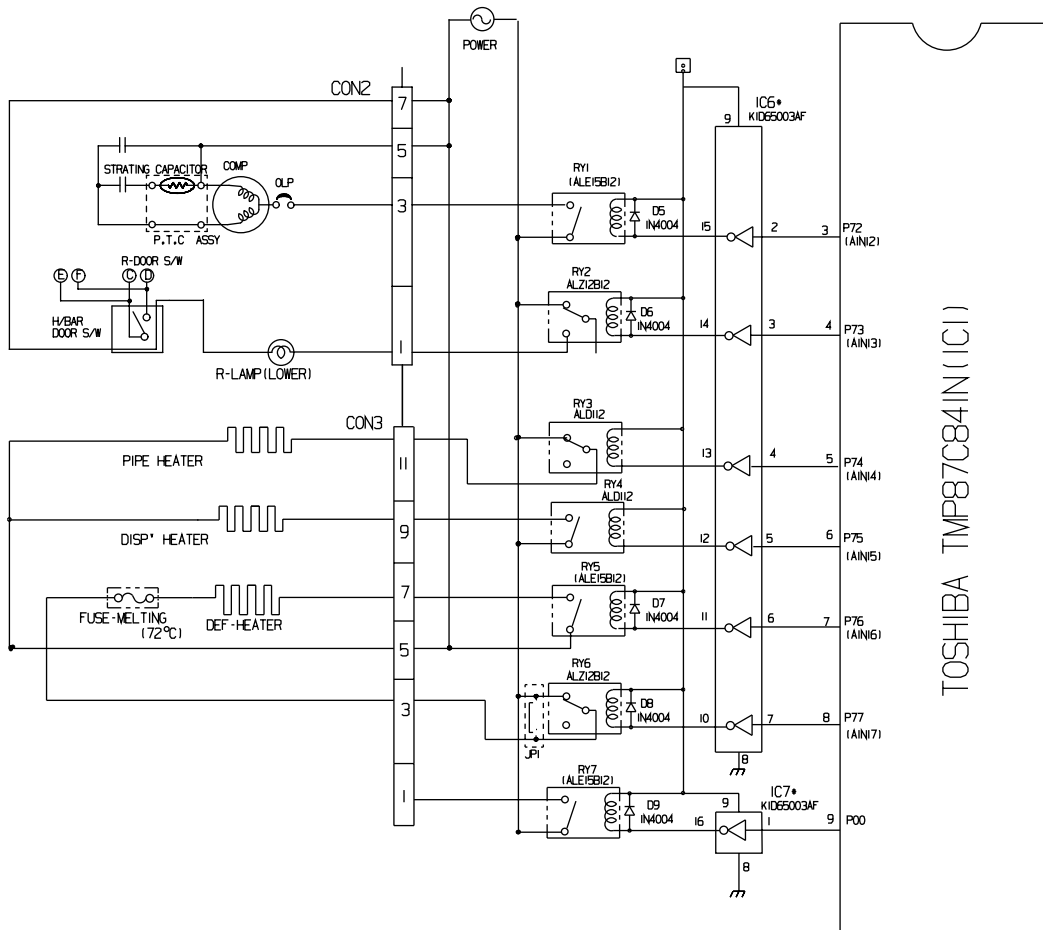

EXPLANATION FOR MICOM CIRCUIT

1-5. Dispenser operation circuit

(1) GR-P227/L227/P257/L257

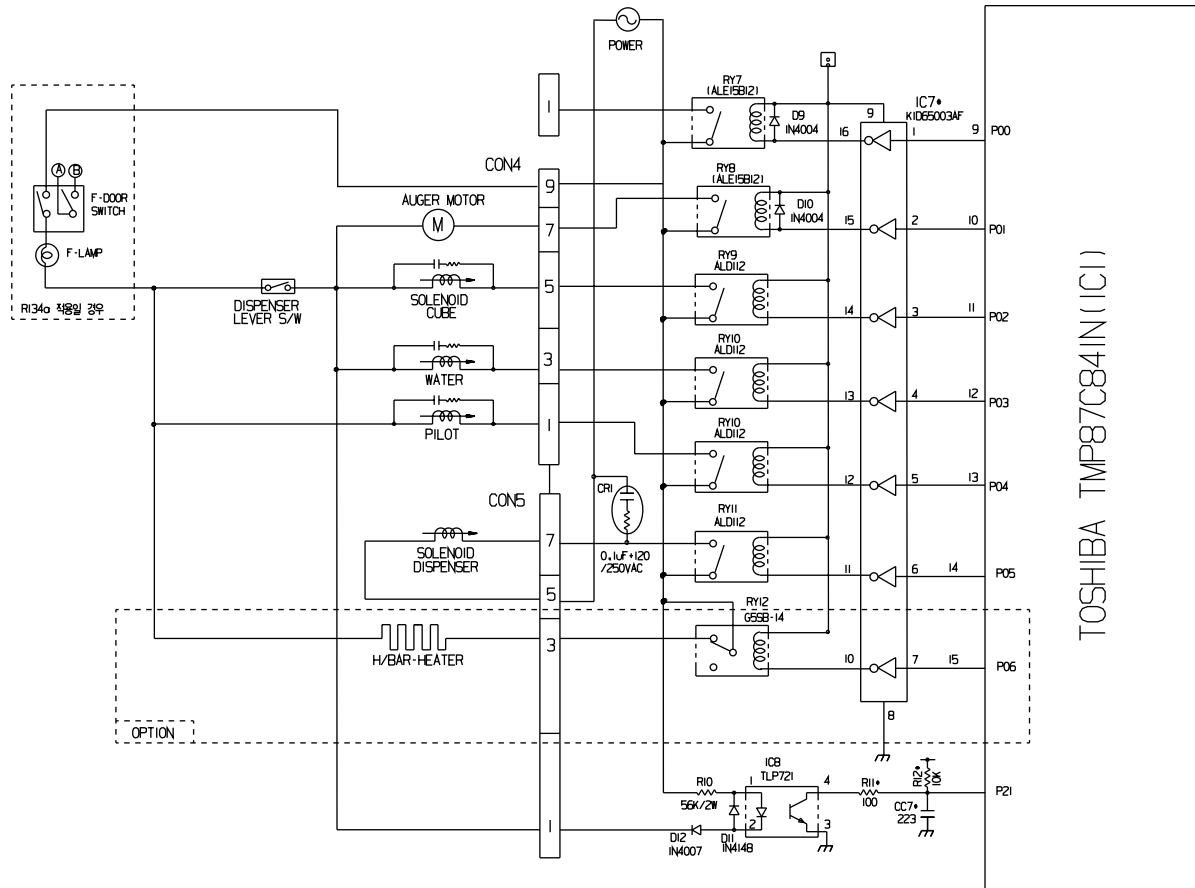

1) Check load driving status

Type of Load	GEARED MOTOR	SOLENOID CUBE	WATER VALVE	PILOT VALVE	SOLENOID DISPENSER
			WATER		
Measuring part	IC7-15	IC7-14	IC7-13	IC7-12	IC7-11
Status	ON	Within 1 V			
	OFF	12 V			

2) Lever Switch sensing circuit

Measuring part	IC1(Micom) (No. 16)	
Lever S/W		
On	5 V	(60 Hz)
OFF	0 V	5V

EXPLANATION FOR MICOM CIRCUIT

1-6. Door opening sensing circuit

(1) GR-P227/L227/P257/L257

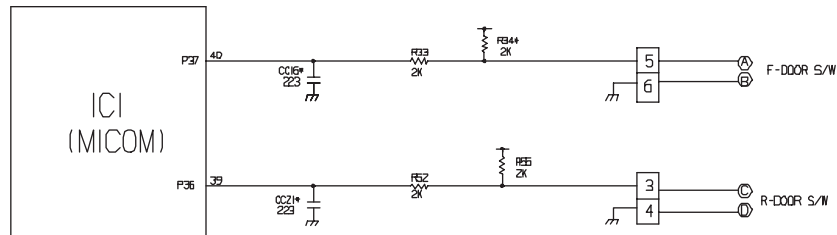

Measuring part	IC1 (MICOM) No. (44, 45) / (45, 46) / (47, 48) Pin
Door of Freezer and Refrigerator	
Closing	5 V (A) - (B), (C) - (D) . Switch at both ends are at Off status)
Opening	0 V (A) - (B), (C) - (D) . Switch at both ends are at On status)

* Since door switches (A) and (B) are interconnected, if either fails, the other will not respond properly.

* If either switch fails, the light will not come on.

EXPLANATION FOR MICOM CIRCUIT

1-7. Temperature sensing circuit

(1) GR-P227/L227/P257/L257

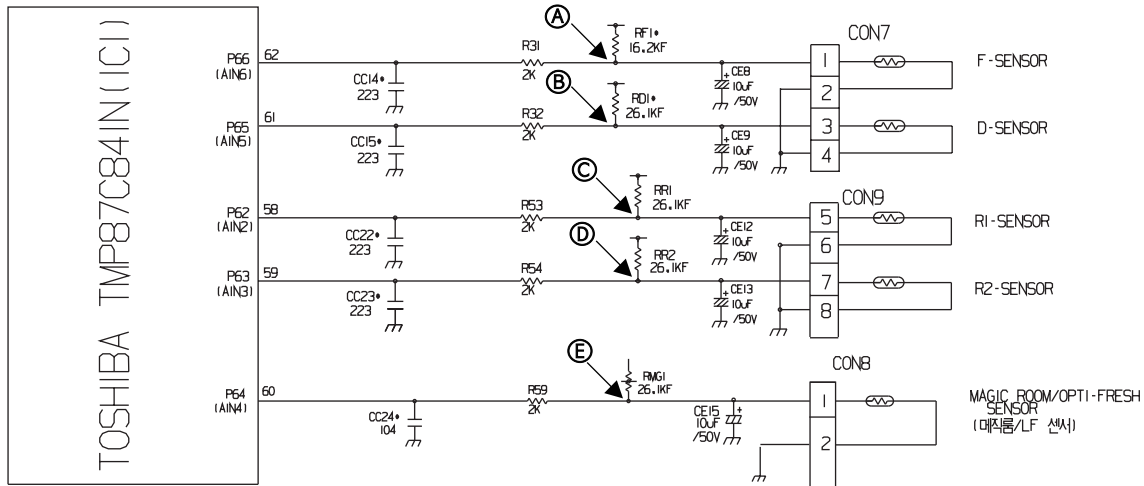

The circuits involving the freezer and refrigerator sensors control the temperature in both the freezer and the refrigerator. The icemaker sensor detects when ice is made. The defrost sensor determines both the need for defrosting and the efficiency of the defrost operation. See the table below for voltages and checkpoints.

SENSOR	CHECK POINT	NORMAL(-22 °F ~ 122 °F)	IN SHORT	IN OPEN
Freezing sensor	POINT (A) Voltage	0.5 V~4.5 V	0 V	5 V
Defrost sensor	POINT (B) Voltage			
Refrigerator sensor 1	POINT (C) Voltage			
Refrigerator sensor 2	POINT (D) Voltage			
Magic room/ Opti Fresh Sensor	POINT (E) Voltage			

EXPLANATION FOR MICOM CIRCUIT

1-8. Switch entry circuit

The following circuits are sensing signal form the damper motor reed switch for testing and diagnosing the refrigerator.

(1) GR-P227/L227/P257/L257

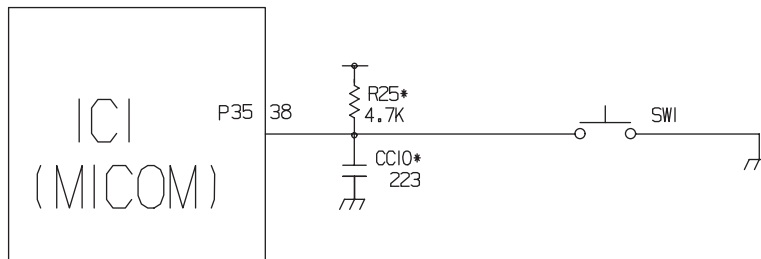

1-9. Option designation circuit (model separation function)

(1) GR-P227/L227/P257/L257

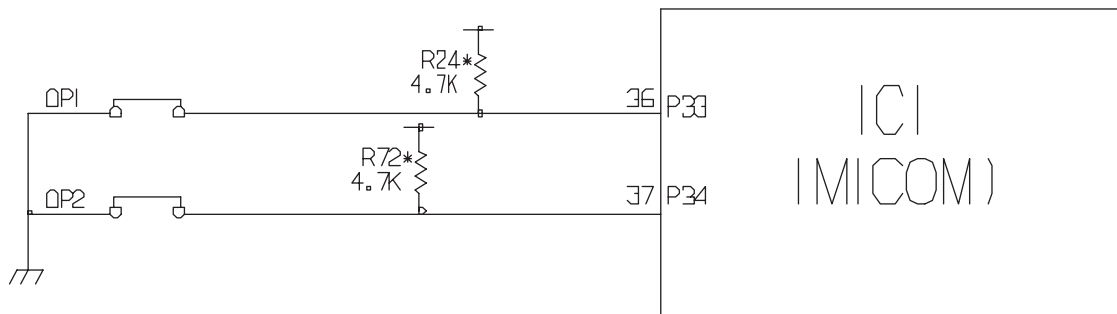

The circuits shown above vary according to which features are included on your particular model.

Separation	Connection Status	Application Standard
OP1	Connection	Miracle Zone exist
	OUT	Miracle Zone don't exist

►These circuits are preset at the factory and cannot be altered.

EXPLANATION FOR MICOM CIRCUIT

1-10. Stepping motor operation circuit

(1) GR-P227/L227/P257/L257

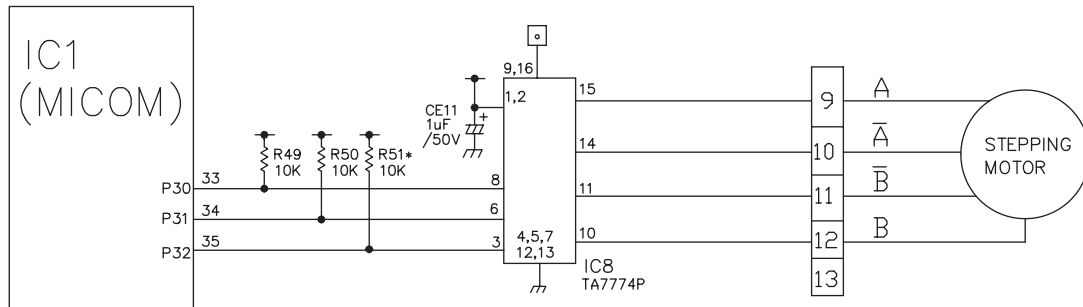

The motor is driven by magnetism formed in the areas of the coils and the stator. Rotation begins when a HIGH signal is applied to MICOM Pin 33 of IC10 (TA7774F). This causes an output of HIGH and LOW signals on MICOM pins 34 and 35.

Explanation) The stepping motor is driven by sending signals of 3.33 mSEC via MICOM pins 33, 34, and 35, as shown in the chart below. These signals are output via terminals 10, 11, 14, and 15 via input terminals 3, 6, and 8 of IC10 (TA7774F), the motor drive chip. The output signals allow the coils wound on each phase of the stator to form a magnetic field, which causes rotation. Input to the terminals INA and INB of IC10 as shown in the chart below drives the motor.

CCW (Reverse rotation) ← ————— → (Positive rotation) CW

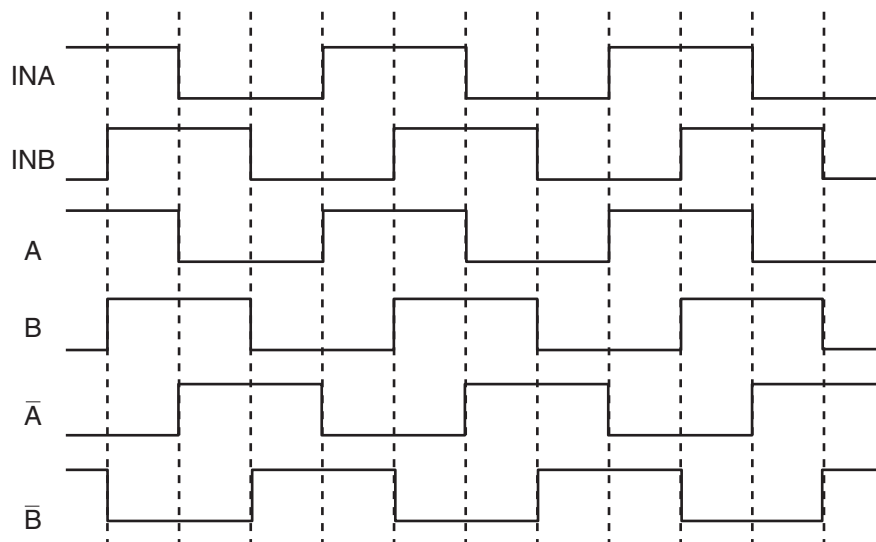

EXPLANATION FOR MICOM CIRCUIT

1-11. Fan motor driving circuit (freezer, mechanical area)

1. The circuit cuts all power to the fan drive IC, resulting in a standby mode.
2. This circuit changes the speed of the fan motor by varying the DC voltage between 7.5 Vdc and 16 Vdc.
3. This circuit stops the fan motor by cutting off power to the fan when it senses a lock-up condition.

	Ⓐ, Ⓓ part	Ⓑ part	Ⓔ part
Motor OFF	5V	2V or less	2V or less
Motor ON	2 ~ 3V	12 ~ 14V	8 ~ 16V

(1) GR-P227/L227/P257/L257

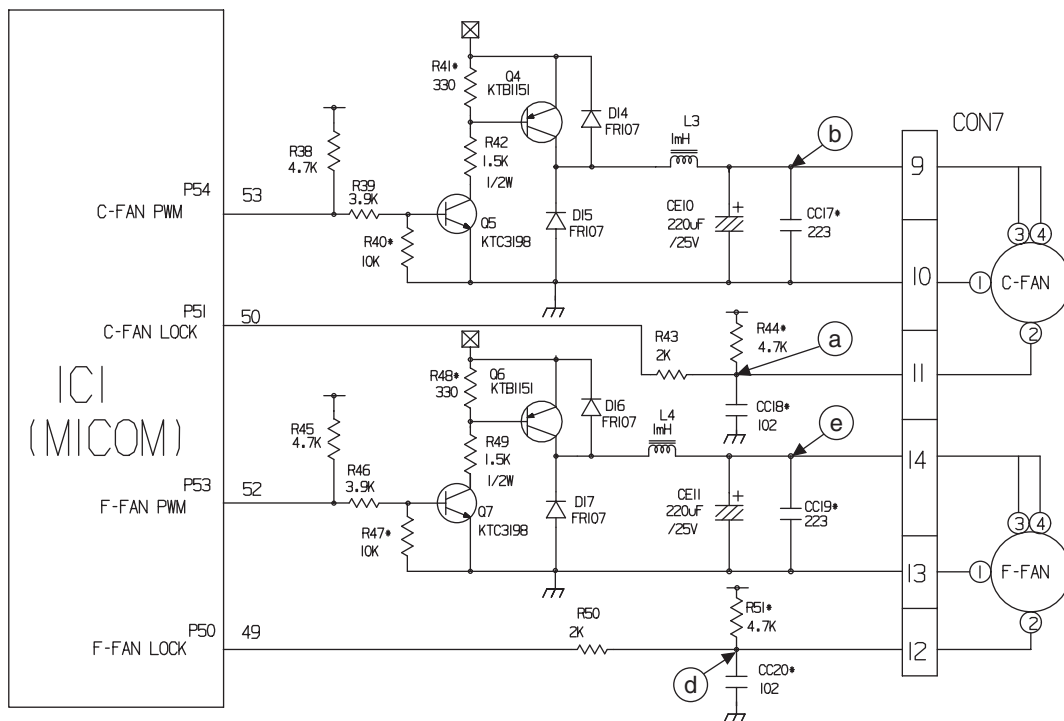

EXPLANATION FOR MICOM CIRCUIT

1-12. Temperature compensation and temperature compensation circuit

1. Temperature compensation in freezer and refrigerator

(1) GR-P227/L227/P257/L257

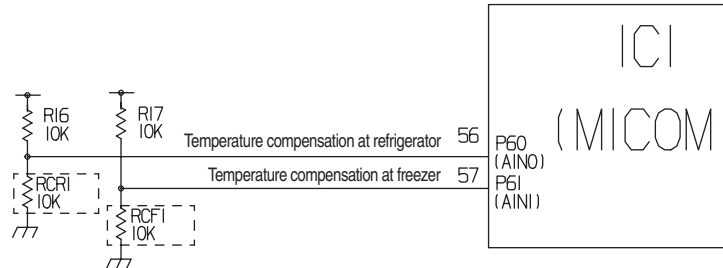

Freezer		Refrigerator		Remarks
Resistance value (RCF1)	Temperature compensation	Resistance value (RCR1)	Temperature compensation	
180 kΩ	+5 °C [+9°F]	180 kΩ	+2.5 °C [+4.5°F]	Warmer ↑
56 kΩ	+4 °C [+7.2°F]	56 kΩ	+2.0 °C [+3.6°F]	
33 kΩ	+3 °C [+5.4°F]	33 kΩ	+1.5 °C [+2.7°F]	
18 kΩ	+2 °C [+3.6°F]	18 kΩ	+1.0 °C [+1.8°F]	
12 kΩ	+1 °C [+1.8°F]	12 kΩ	+0.5 °C [+0.9°F]	
10 kΩ	0 °C [0°F]	10 kΩ	0 °C [0°F]	Reference temperature
8.2 kΩ	-1 °C [-1.8°F]	8.2 kΩ	-0.5 °C [-0.9°F]	Cooler ↓
5.6 kΩ	-2 °C [-3.6°F]	5.6 kΩ	-1.0 °C [-1.8°F]	
3.3 kΩ	-3 °C [-5.4°F]	3.3 kΩ	-1.5 °C [-2.7°F]	
2 kΩ	-4 °C [-7.2°F]	2 kΩ	-2.0 °C [-3.6°F]	
470 Ω	-5 °C [-9°F]	470 Ω	-2.5 °C [-4.5°F]	

► Temperature compensation table by adjustment value (difference value against current temperature)

Ex) If you change compensation resistance at a refrigerator (RCR1) from 10 kΩ (current resistance) to 18 kΩ (modified resistance), the temperature at the refrigerator will increase by +1°C[+1.8°F].

EXPLANATION FOR MICOM CIRCUIT

► Temperature compensation table at the refrigerator is as follows:

	Modification resistance	470 Ω	2 kΩ	3.3 kΩ	5.6 kΩ	8.2 kΩ	10 kΩ	12 kΩ	18 kΩ	33 kΩ	56 kΩ	180 kΩ
	Current resistance											
Refrigerator (RCR1)	470Ω	No change	0.5 °C [0.9 °F] Up	1 °C [1.8 °F] Up	1.5 °C [2.7 °F] Up	2 °C [3.6 °F] Up	2.5 °C [4.5 °F] Up	3 °C [5.4 °F] Up	3.5 °C [6.3 °F] Up	4 °C [7.2 °F] Up	4.5 °C [8.1 °F] Up	5 °C [9 °F] Up
	2 kΩ	0.5 °C [0.9 °F] Down	No change	0.5 °C [0.9 °F] Up	1 °C [1.8 °F] Up	1.5 °C [2.7 °F] Up	2 °C [3.6 °F] Up	2.5 °C [4.5 °F] Up	3 °C [5.4 °F] Up	3.5 °C [6.3 °F] Up	4 °C [7.2 °F] Up	4.5 °C [8.1 °F] Up
	3.3 kΩ	1 °C [1.8 °F] Down	0.5 °C [0.9 °F] Down	No change	0.5 °C [0.9 °F] Up	1 °C [1.8 °F] Up	1.5 °C [2.7 °F] Up	2 °C [3.6 °F] Up	2.5 °C [4.5 °F] Up	3 °C [5.4 °F] Up	3.5 °C [6.3 °F] Up	4 °C [7.2 °F] Up
	5.6 kΩ	1.5 °C [2.7 °F] Down	1 °C [1.8 °F] Down	0.5 °C [0.9 °F] Down	No change	0.5 °C [0.9 °F] Up	1 °C [1.8 °F] Up	1.5 °C [2.7 °F] Up	2 °C [3.6 °F] Up	2.5 °C [4.5 °F] Up	3 °C [5.4 °F] Up	3.5 °C [6.3 °F] Up
	8.2 kΩ	2 °C [3.6 °F] Down	1.5 °C [2.7 °F] Down	1 °C [1.8 °F] Down	0.5 °C [0.9 °F] Drop	No change	0.5 °C [0.9 °F] Up	1 °C [1.8 °F] Up	1.5 °C [2.7 °F] Up	2 °C [3.6 °F] Up	2.5 °C [4.5 °F] Up	3 °C [5.4 °F] Up
	10 kΩ	2.5 °C [4.5 °F] Down	2 °C [3.6 °F] Down	1.5 °C [2.7 °F] Down	1 °C [1.8 °F] Down	0.5 °C [0.9 °F] Down	No change	0.5 °C [0.9 °F] Up	1 °C [1.8 °F] Up	1.5 °C [2.7 °F] Up	2 °C [3.6 °F] Up	2.5 °C [4.5 °F] Up
	12 kΩ	3 °C [5.4 °F] Down	2.5 °C [4.5 °F] Down	2 °C [3.6 °F] Down	1.5 °C [2.7 °F] Down	1 °C [1.8 °F] Down	0.5 °C [0.9 °F] Down	No change	0.5 °C [0.9 °F] Up	1 °C [1.8 °F] Up	1.5 °C [2.7 °F] Up	2 °C [3.6 °F] Up
	18 kΩ	3.5 °C [6.3 °F] Down	3 °C [5.4 °F] Down	2.5 °C [4.5 °F] Down	2 °C [3.6 °F] Down	1.5 °C [2.7 °F] Down	1 °C [1.8 °F] Down	0.5 °C [0.9 °F] Down	No change	0.5 °C [0.9 °F] Up	1 °C [1.8 °F] Up	1.5 °C [2.7 °F] Up
	33 kΩ	4 °C [7.2 °F] Down	3.5 °C [6.3 °F] Down	3 °C [5.4 °F] Down	2.5 °C [4.5 °F] Down	2 °C [3.6 °F] Down	1.5 °C [2.7 °F] Down	1 °C [1.8 °F] Down	0.5 °C [0.9 °F] Down	No change	0.5 °C [0.9 °F] Up	1 °C [1.8 °F] Up
	56 kΩ	4.5 °C [8.1 °F] Down	4 °C [7.2 °F] Down	3.5 °C [6.3 °F] Down	3 °C [5.4 °F] Down	2.5 °C [4.5 °F] Down	2 °C [3.6 °F] Down	1.5 °C [2.7 °F] Down	1 °C [1.8 °F] Down	0.5 °C [0.9 °F] Down	No change	0.5 °C [0.9 °F] Up
180 kΩ	5 °C [9 °F] Down	4.5 °C [8.1 °F] Down	4 °C [7.2 °F] Down	3.5 °C [6.3 °F] Down	3 °C [5.4 °F] Down	2.5 °C [4.5 °F] Down	2 °C [3.6 °F] Down	1.5 °C [2.7 °F] Down	1 °C [1.8 °F] Down	0.5 °C [0.9 °F] Down	No change	

► Temperature compensation at the freezer is performed the same as at the refrigerator. The value for the freezer is twice that of the refrigerator.

► This circuit enters the necessary level of temperature compensation for adjusting the appliance. The method is the same for every model in this appliance family.

EXPLANATION FOR MICOM CIRCUIT

2. Compensation circuit for temperature at freezer

(1) GR-P227/L227/P257/L257

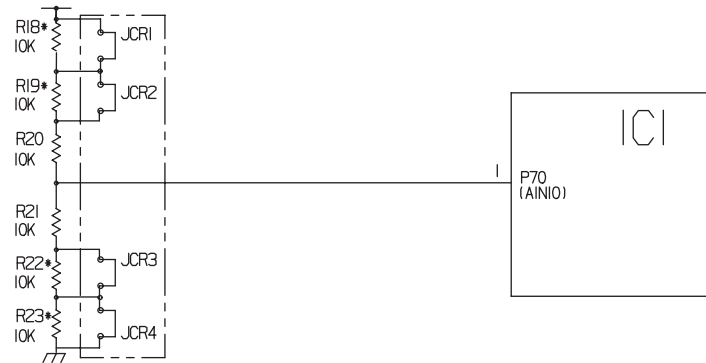

Temperature compensation in CUT		
JCR1	+1 °C [+1.8 °F]	+2 °C [+3.6 °F]
JCR2	+1 °C [+1.8 °F]	
JCR3	-1 °C [-1.8 °F]	-2 °C [-3.6 °F]
JCR4	-1 °C [-1.8 °F]	

Compensation for too warm		Compensation for too cold		Temperature compensation value at refrigerator	Remarks
JCR3	JCR4	JCR1	JCR2		
<input type="checkbox"/>	<input type="checkbox"/>	<input type="checkbox"/>	<input type="checkbox"/>	0 °C [In shipment from factory]	
CUT	<input type="checkbox"/>	<input type="checkbox"/>	<input type="checkbox"/>	-1 °C [-1.8 °F]	
<input type="checkbox"/>	CUT	<input type="checkbox"/>	<input type="checkbox"/>	-1 °C [-1.8 °F]	
<input type="checkbox"/>	<input type="checkbox"/>	CUT	<input type="checkbox"/>	+1 °C [+1.8 °F]	
<input type="checkbox"/>	<input type="checkbox"/>	<input type="checkbox"/>	CUT	+1 °C [+1.8 °F]	
CUT	CUT	<input type="checkbox"/>	<input type="checkbox"/>	-2 °C [-3.6 °F]	
<input type="checkbox"/>	<input type="checkbox"/>	CUT	CUT	+2 °C [+3.6 °F]	
CUT	<input type="checkbox"/>	CUT	<input type="checkbox"/>	0 °C [0 °F]	
CUT	<input type="checkbox"/>	<input type="checkbox"/>	CUT	0 °C [0 °F]	
<input type="checkbox"/>	CUT	CUT	<input type="checkbox"/>	0 °C [0 °F]	
<input type="checkbox"/>	CUT	<input type="checkbox"/>	CUT	0 °C [0 °F]	
CUT	CUT	CUT	<input type="checkbox"/>	-1 °C [-1.8 °F]	
<input type="checkbox"/>	CUT	CUT	CUT	+1 °C [+1.8 °F]	
CUT	CUT	CUT	CUT	0 °C [0 °F]	

► This circuit allows adjustment of the set temperature for compensation by changing jumpers at locations JCR1~JCR4.

EXPLANATION FOR MICOM CIRCUIT

1-13. Communication circuit and connection L/Wire between main PCB and display PCB

The following communication circuit is used for exchanging information between the main MICOM of the Main PCB and the dedicated MICOM of the LED (LCD) Display PCB.

A bi-directional lead wire assembly between the two boards is required for the display to function properly.

Poor communication occurs if a continuous information exchange fail to continue for more than 2 minutes between main MICOM of main PCB and LCD (LED) dedicated MICOM for LCD (LED) control of display PCB.

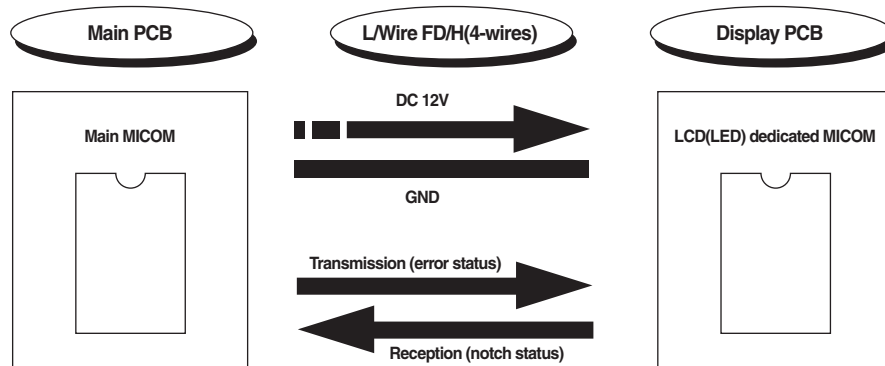

(1) GR-P227/L227/P257/L257

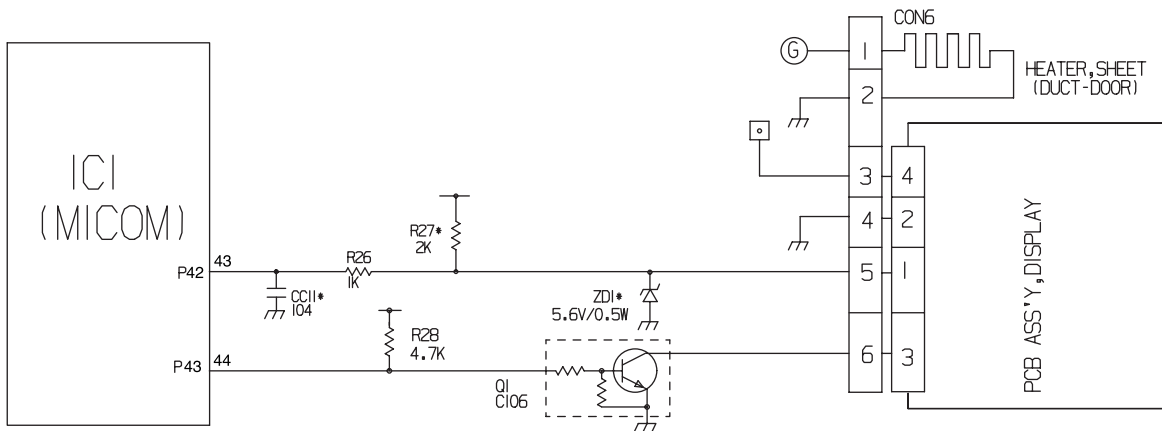

EXPLANATION FOR MICOM CIRCUIT

2) Sensor resistance characteristics table

Measuring Temperature (°C)	Freezing Sensor	Refrigerator sensor 1&2 Defrost sensor, Ambient sensor
-20 °C	22.3 kΩ	77 kΩ
-15 °C	16.9 kΩ	60 kΩ
-15 °C	13.0 kΩ	47.3 kΩ
-5 °C	10.1 kΩ	38.4 kΩ
0 °C	7.8 kΩ	30 kΩ
+5 °C	6.2 kΩ	24.1 kΩ
+10 °C	4.9 kΩ	19.5 kΩ
+15 °C	3.9 kΩ	15.9 kΩ
+20 °C	3.1 kΩ	13 kΩ
+25 °C	2.5 kΩ	11 kΩ
+30 °C	2.0 kΩ	8.9 kΩ
+40 °C	1.4 kΩ	6.2 kΩ
+50 °C	0.8 kΩ	4.3 kΩ

- ▶ Resistance value allowance of sensor is $\pm 5\%$.
- ▶ When measuring the resistance value of the sensor, allow the temperature of that sensor to stabilize for at least 3 minutes before measuring. This delay is necessary because of the sense speed relationship.
- ▶ Use a digital tester to measure the resistance. An analog tester has to great a margin of error.
- ▶ Resistance of the cold storage sensor 1 and 2 shall be measured with a digital tester after separating CON8 of the PWB ASSEMBLY and the MAIN part.
- ▶ Resistance of the freezing sensor shall be measured with a digital tester after separating CON7 of the PWB ASSEMBLY and the MAIN part.

EXPLANATION FOR MICOM CIRCUIT

1-14. Miracle Zone STEPPING MOTOR / Display

Miracle zone stepping motor damper is same as 1-8 stepping motor operation circuit and the miracle zone display turns on only when the R-door opens.

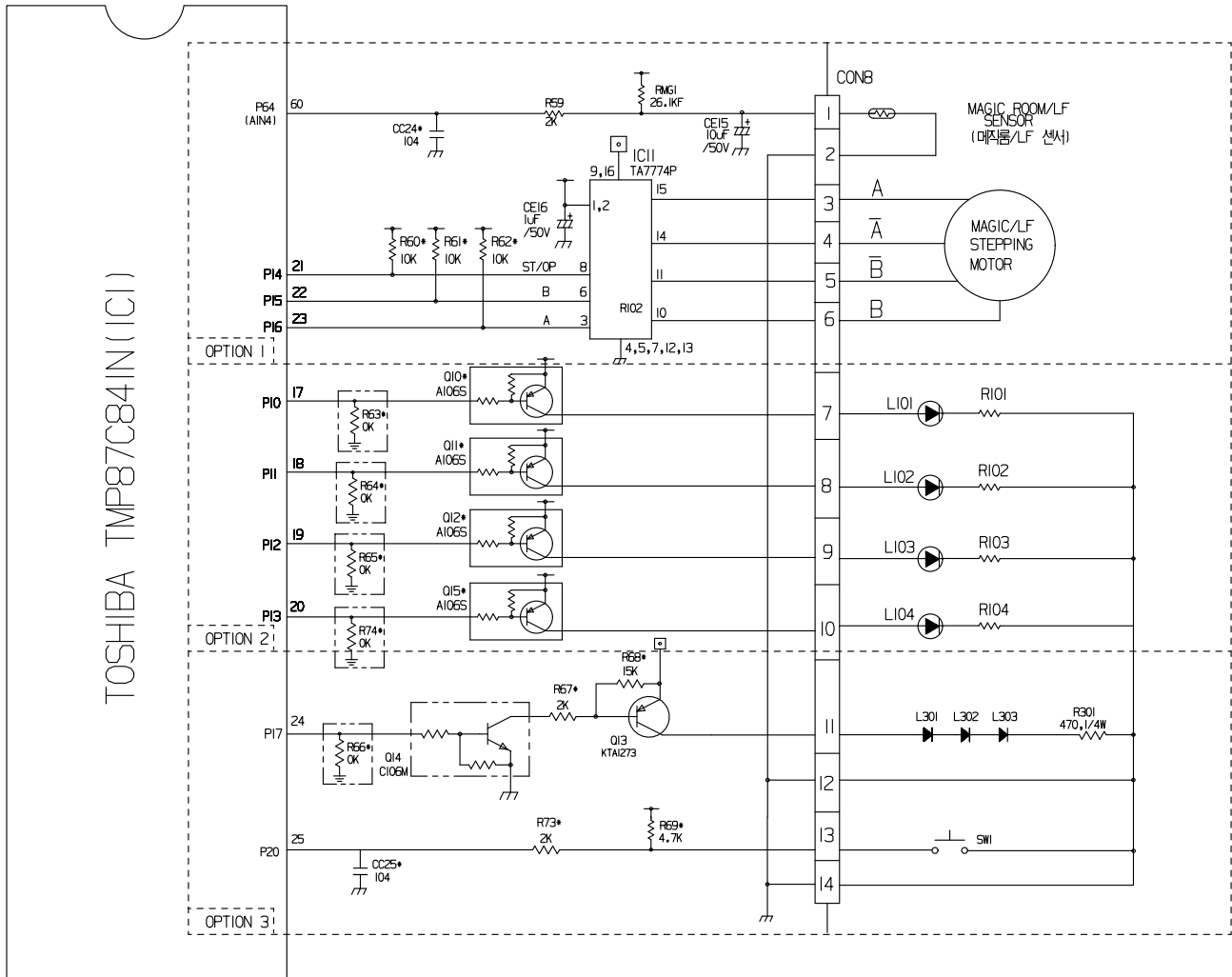

ICEMAKER AND DISPENSER WORKING PRINCIPLES AND REPAIR

1. Operation Principle

1-1. Operation Principle of Icemaker

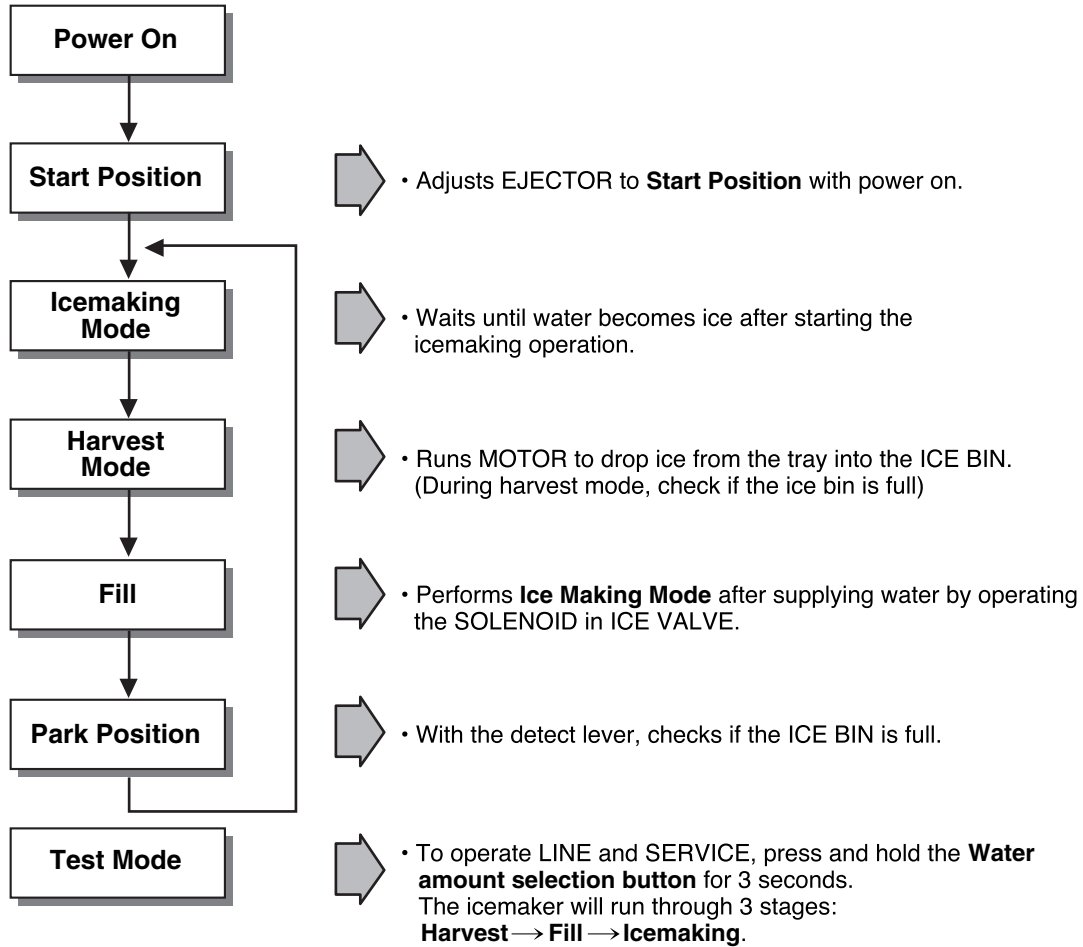

1. Turning the Icemaker switch off (O) stops the ice making function.
2. Setting the Icemaker switch to OFF and then turning it back on will reset the icemaker control.

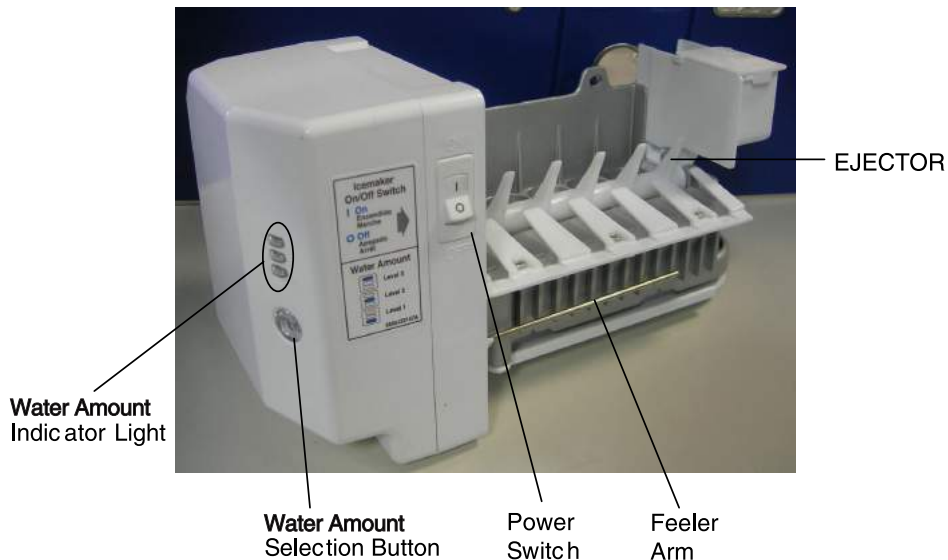

ICEMAKER AND DISPENSER WORKING PRINCIPLES AND REPAIR

2. ICEMAKER FUNCTIONS

2-1. Start Position

1. After POWER OFF or power outage, check the EJECTOR's position with MICOM initialization to restart.
2. How to check if it is in place:
 - Check **HIGH/LOW** signals from HALL SENSOR in MICOM PIN.
3. Control Method to check if it is in place:
 - (1) EJECTOR is in place,
 - It is an initialized control, so the mode can be changed to icemaking mode.
 - (2) EJECTOR isn't in place:
 - A. If EJECTOR is back in place within 2 minutes with the motor on, it is being initialized. If not, go to Step B.
 - B. Control the heater using the temperature sensor until the EJECTOR reaches the correct location.

2-2. Icemaking Mode

1. Icemaking refers to the freezing of supplied water in the ice tray. Complete freezing is assured by measuring the temperature of the Tray with Icemaking SENSOR.
2. Icemaking starts after completion of the water fill operation.
3. The Ice Making function is completed when the sensor reaches 19°F (-7°C), 55 minutes after starting.

NOTE : After Icemaker Power is ON, the Icemaker heater will be on for test for 6 sec.



2-3. Harvest Mode

1. Harvest (Ice removing) refers to the operation of dropping ices into the ice bin from the tray when icemaking has completed.
 2. Harvest mode:
 - (1) The Heater is ON for 30 seconds, then the motor starts.
 - (2) The feeler arm senses the quantity of ice in the ice bin while rotating with the EJECTOR.
 - A. ice bin is full : The EJECTOR stops (heater off).
 - B. ice bin is not full : The EJECTOR rotates twice to open for ice.
- ※ If the EJECTOR does not rotate once within 5 minutes in B mode, separate heater control mode starts operating to prevent the EJECTOR from being constrained. (It is recommended that the user open for ice to return to normal mode.)

2-4. Fill/Park Position

1. Once a normal harvest mode has been completed, the water solenoid will be activated.
2. The amount of water is adjusted by pressing the Fill Key repeatedly. This changes the time allowed for fill as illustrated in the table below.

Water supply amount TABLE





STAGE	TIME TO SUPPLY	INDICATIONS	REMARKS
1	5 sec.		The water amount will vary depending on the water control switch setting, as well as the water pressure of the connected water line.
2	5.5 sec. (FIRST STAGE)		
3	6 sec.		

ICEMAKER AND DISPENSER WORKING PRINCIPLES AND REPAIR

2-5. Function TEST

1. This is a forced operation for TEST, Service, cleaning, etc. It is operated by pressing and holding the Water amount selection button for 3 seconds.
2. The test works only in the Icemaking Mode. It cannot be entered from the Harvest or Fill mode. (If there is an ERROR, it can only be checked in the TEST mode.)
3. **Caution!** If the test is performed before water in the ice tray is frozen, the ejector will just pass through the water. When the Fill mode begins (Stage 4), unless the water supply has been shut off, added water will overflow into the ice bin. If the control doesn't operate normally in the TEST mode, check and repair as needed.
4. After water is supplied, the normal CYCLE is followed: **icemaking** → **Harvest** → **Fill** → **Park Position**.
5. After Stage 5 is completed, the Ice Maker returns to MICOM control. The time needed to supply water resets to the pre-test setting.
6. This icemaker function test takes about 90 seconds in case, there aren't ices in the ice tray. If there are ices in the ice tray, it can take more than 90 seconds.

Diagnosis TABLE

STAGE	ITEMS	INDICATOR	REMARKS
1	HEATER		Five seconds after heater starts, a heater will go off if the temperature by sensor is higher than 10°C
2	MOTOR		Five seconds after heater starts, you can confirm that a motor is moving.
3	HALL IC I (detection of position)		After the icemaker detects that ice has been made, the motor and heater are off but on standby until the cycle is cancelled.
4	HALL IC II (detection of position)		You can confirm HALL IC detection of position.
5	VALVE		Two seconds after detection of initial position, you can confirm that valve is on.
6	Reset	Return to Status prior to TEST MODE	Five seconds after fifth stage is completed, The icemaker resets to initial status.

3. Defect diagnosis function

3-1. ERROR CODES shown on Icemaker water supply control panel

NO	DIVISION	INDICATOR	CONTENTS	REMARKS
1	Normal	Mark time to supply	None	Display switch operates properly
2	Icemaking Sensor malfunction		Open or short-circuited wire	Make sure that the wire on each sensor is connected.

ERROR indicators in table can be checked only in TEST mode.

CIRCUIT

(1) GR-P227/L227/P257/L257GR-P227/L227/P257/L257

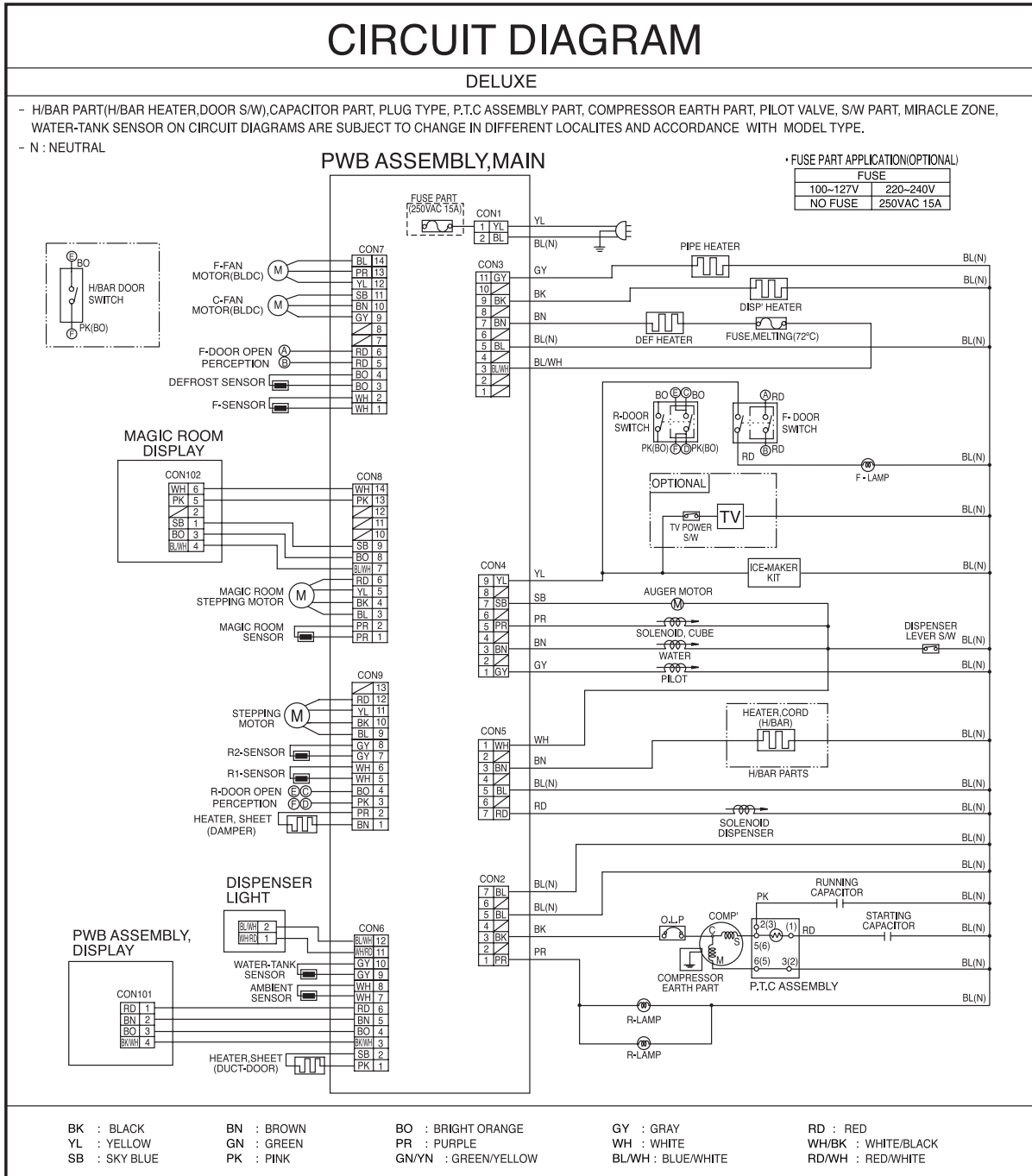

TROUBLE DIAGNOSIS

1. Trouble Shooting

CLAIMS.	CAUSES AND CHECK POINTS.	HOW TO CHECK
<p>1. Faulty start</p>	<p>1) No power on outlet. 2) No power on cord.</p> <ul style="list-style-type: none"> - Bad connection between adapter and outlet. (faulty adapter) <ul style="list-style-type: none"> - The Inner diameter of adapter. - The distance between holes. - The distance between terminals. - The thickness of terminal. - Bad connection between plug and adapter (faulty plug). <ul style="list-style-type: none"> - The distance between pins. - Pin outer diameter. <p>3) Shorted start circuit.</p> <ul style="list-style-type: none"> - No power on power cord. <ul style="list-style-type: none"> - Disconnected copper wire. <ul style="list-style-type: none"> - Power cord is disconnected. - Faulty soldering. - Internal electrical short. - Faulty terminal contact. <ul style="list-style-type: none"> - Loose contact. <ul style="list-style-type: none"> - Large distance between male terminal. - Thin female terminal. - Terminal disconnected. - Bad sleeve assembly. - Disconnected. <ul style="list-style-type: none"> - Weak connection. - Short inserted cord length. - Worn out tool blade. - O.L.P is off. <ul style="list-style-type: none"> - Capacity of O.L.P is small. - Characteristics of O.L.P is bad. - Bad connection. - Power is disconnected. <ul style="list-style-type: none"> - Inner Ni-Cr wire blows out. - Bad internal connection. - Faulty terminal caulking (Cu wire is cut). - Bad soldering. - No electric power on compressor. - Faulty compressor. - Faulty PTC. <ul style="list-style-type: none"> - Power does not conduct. - Damage. - Bad characteristics. - Initial resistance is big. - Bad connection with compressor. <ul style="list-style-type: none"> - Too loose. - Assembly is not possible. - Bad terminal connection. <p>4) During defrost.</p> <ul style="list-style-type: none"> - Start automatic defrost. - Cycle was set at defrost when the refrigerator was produced. 	<p>* Measuring instrument : Multi tester</p> <p>■ Check the voltage. If the voltage is within $\pm 85\%$ of the rated voltage, it is OK.</p> <p>■ Check the terminal movement.</p> <p>■ Check both terminals of power cord. Power conducts : OK. No power conducts : NG</p> <p>■ Check both terminals of O.L.P. If power conducts : OK. If not : NG.</p> <p>■ Check the resistance of both terminals. At normal temperature 6 : OK. If disconnected : ∞.</p>

TROUBLE DIAGNOSIS

CLAIMS.	CAUSES AND CHECK POINTS.	HOW TO CHECK
<p>2. No cooling.</p>	<p>2) Refrigeration system is clogged.</p> <ul style="list-style-type: none"> - Moisture clogged. <ul style="list-style-type: none"> - Residual moisture in the evaporator. <ul style="list-style-type: none"> - Air Blowing. <ul style="list-style-type: none"> - Not performed. - Too short. - Impossible moisture confirmation. - Low air pressure. - Leave it in the air. <ul style="list-style-type: none"> - During rest time. - After work. - Caps are missed. - Residual moisture. <ul style="list-style-type: none"> - Not dried in the compressor. - Elapsed more than 6 months after drying - Caps are missed. - No pressure when it is open. - No electric power on thermostat. <ul style="list-style-type: none"> - Insufficient drier capacity. <ul style="list-style-type: none"> - Dry drier - Drier temperature. - Leave it in the air. <ul style="list-style-type: none"> - Check on package condition. - Good storage after finishing. - Residual moisture in pipes. <ul style="list-style-type: none"> - Caps are missed. <ul style="list-style-type: none"> - During transportation. - During work. - Air blowing. <ul style="list-style-type: none"> - Not performed. - Performed. <ul style="list-style-type: none"> - Too short time. - Low air pressure. - Less dry air. - Moisture penetration - Leave it in the air. - Moisture penetration into the refrigeration oil. - Weld joint clogged. <ul style="list-style-type: none"> - Short pipe insert. - Pipe gaps. <ul style="list-style-type: none"> - Too large. - Damaged pipes. - Too much solder. - Drier cloggeing. <ul style="list-style-type: none"> - The capillary tube inserted depth. - Too much. - Capillary tube melts. - Over heat. - Clogged with foreign materials. <ul style="list-style-type: none"> - Desiccant powder. - Weld oxides. - Drier angle. - Reduced cross section by cutting. - Squeezed. - Foreign material clogging. <ul style="list-style-type: none"> - Compressor cap is disconnected. - Foreign materials are in the pipe. 	<ul style="list-style-type: none"> ■ Check the clogged evaporator by heating (as soon as the cracking sound begins, the evaporator start freezing) ■ The evaporator does not cool from the beginnig (no evidence of misture attached). The evaporator is the same as before even heat is applied.

TROUBLE DIAGNOSIS

CLAIMS.	CAUSES AND CHECK POINTS.	HOW TO CHECK
<p>3. Refrigeration is weak.</p>	<p>1) Refrigerant Partly leaked. ┌ Weld joint leak. └ Parts leak.</p> <p>2) Poor defrosting capacity.</p> <p style="margin-left: 20px;">┌ Drain path (pipe) clogged. ┌ Inject P/U into drain hose. ┌ Inject through the hole. └ Seal with drain.</p> <p style="margin-left: 60px;">└ Foreign materials penetration. ┌ P/U lump input. └ Screw input. └ Other foreign materials input.</p> <p style="margin-left: 20px;">└ Cap drain is not disconnected.</p> <p style="margin-left: 20px;">┌ Defrost heater does not generate heat. ┌ Parts disconnected. ┌ Heater Sheath ┌ Wire is cut. └ Lead wire. └ Heating wire. └ Contact point between heating and electric wire. └ Dent by fin evaporator. └ Heating wire is corroded. └ Water penetration. └ Bad terminal connection.</p>	<p>■ Check visually.</p> <p>■ Check terminal Conduction: OK. No conduction: NG. If wire is not cut, refer to resistance. P=Power V=Voltage R=Resistance</p> $P = \frac{V^2}{R}$ $R = \frac{V^2}{P}$

TROUBLE DIAGNOSIS

CLAIMS.	CAUSES AND CHECK POINTS.	HOW TO CHECK
<p>3. Refrigeration is weak.</p>	<ul style="list-style-type: none"> Residual frost. <ul style="list-style-type: none"> Weak heat from heater. <ul style="list-style-type: none"> Sheath Heater - rated. Heater plate - rated. Too short defrosting time. <ul style="list-style-type: none"> Defrost Sensor. <ul style="list-style-type: none"> - Faulty characteristics. Seat-D(missing, location, thickness). Structural fault. <ul style="list-style-type: none"> Gasket gap. Air inflow through the fan motor. Bad insulation of case door. No automatic defrosting. Defrost does not return. <p>3) Cooling air leak.</p> <ul style="list-style-type: none"> Bad gasket adhesion <ul style="list-style-type: none"> Gap. Bad attachment. Contraction. Door sag. <ul style="list-style-type: none"> Bad adhesion. Weak binding force at hinge. <p>4) No cooling air circulation.</p> <ul style="list-style-type: none"> Faulty fan motor. <ul style="list-style-type: none"> Fan motor. <ul style="list-style-type: none"> Self locked. Wire is cut. Bad terminal contact. Door switch. <ul style="list-style-type: none"> Faults. <ul style="list-style-type: none"> Contact distance. Button pressure. Melted contact. Contact. Refrigerator and freezer switch reversed. Button is not pressed. <ul style="list-style-type: none"> Poor door attachment. Door liner (dimension). Contraction inner liner. Misalignment. Bad terminal connection. P/U liquid leak. 	<p>■ Check the fan motor conduction: OK. No conduction: NG.</p>

TROUBLE DIAGNOSIS

CLAIMS.	CAUSES AND CHECK POINTS.	HOW TO CHECK
<p>3. Refrigeration is weak.</p>	<p>4) No cooling air circulation.</p> <ul style="list-style-type: none"> — Faulty fan motor. — Fan is constrained. <ul style="list-style-type: none"> — Fan shroud contact. - Clearance. — Damping evaporator contact. — Accumulated residual frost. — Small cooling air discharge. <ul style="list-style-type: none"> — Insufficient motor RPM <ul style="list-style-type: none"> — Fan overload. - Fan misuse. — Bad low temperature RPM characteristics. — Rated power misuse. — Low voltage. — Faulty fan. <ul style="list-style-type: none"> — Fan misuse. — Bad shape. — Loose connection. - Not tightly connected. — Insert depth. — Shroud. — Bent. — Ice and foreign materials on rotating parts. <p>5) Compressor capacity. <ul style="list-style-type: none"> — Rating misuse. — Small capacity. — Low voltage. </p> <p>6) Refrigerant too much or too little. <ul style="list-style-type: none"> — Malfunction of charging cylinder. — Wrong setting of refrigerant. — Insufficient compressor. - Faulty compressor. </p> <p>7) Continuous operation <ul style="list-style-type: none"> - No contact of temperature controller. - Foreign materials. </p> <p>8) Damper opens continuously. <ul style="list-style-type: none"> — Foreign materials jammed. <ul style="list-style-type: none"> — P/U liquid dump. — EPS water sediment. — Screw. — Failed sensor. - Position of sensor. — Characteristics of damper. <ul style="list-style-type: none"> — Bad characteristics of its own temperature. — Parts misuse. — Change of temperature - Impact characteristics. </p> <p>9) Food storing place. - Near the outlet of cooling air.</p>	<p>■ Check visually after disassembly.</p> <p>■ Check visually after disassembly.</p>

TROUBLE DIAGNOSIS

CLAIMS.	CAUSES AND CHECK POINTS.	HOW TO CHECK
<p>4. Warm refrigerator compartment temperature.</p>	<p>1) Colgged cooling path. <ul style="list-style-type: none"> └ P/U liquid leak. └ Foreign materials. — P/U dump liquid. </p> <p>2) Food storate. <ul style="list-style-type: none"> └ Store hot food. └ Store too much at once. └ Door open. └ Packages block air flow. </p>	
<p>5. No automatic operation. (faulty contacts.)</p>	<p>1) Faulty temperature sensor in freezer or refrigerator compartment. <ul style="list-style-type: none"> └ Faulty contact. └ Faulty temperature characteristics. </p> <p>2) Refrigeration load is too much. <ul style="list-style-type: none"> └ Food. <ul style="list-style-type: none"> └ Too much food. └ Hot food. └ Frequent opening and closing. └ Cool air leak. └ Poor door close. — Partly opens. </p> <p>3) Poor insulation.</p> <p>4) Bad radiation. <ul style="list-style-type: none"> └ High ambient temperature. └ Space is secluded. </p> <p>5) Refrigerant leak.</p> <p>6) Inadequate of refrigerant.</p> <p>7) Weak compressor discharging power. <ul style="list-style-type: none"> └ Different rating. └ Small capacity. </p> <p>8) Fan does not work.</p> <p>9) Button is positioned at "strong."</p>	<p>■ Inspect parts measurements and check visually.</p>
<p>6. Dew and ice formation.</p>	<p>1) Ice in freezer compartment. <ul style="list-style-type: none"> └ External air inflow. — Rubber motor assembly direction(reverse). └ Door opens but not closes. <ul style="list-style-type: none"> └ Weak door closing power. └ Stopper malfunction. └ Door sag. └ Food hinders door closing. └ Gap around gasket. — Contraction, distortion, loose, door twisted, corner not fully inserted. └ Food vapor. — Storing hot food. — Unsealed food. </p> <p>2) Condensation in the refrigerator compartment. <ul style="list-style-type: none"> └ Door opens but not closes. <ul style="list-style-type: none"> └ Insufficient closing. └ Door sag. └ Food hinders door closing. └ Gasket gap. </p> <p>3) Condensation on liner foam. <ul style="list-style-type: none"> └ Cool air leak and transmitted. <ul style="list-style-type: none"> └ Not fully filled. <ul style="list-style-type: none"> └ Toop table part. └ Out plate R/L part. └ Flange gap. — Not sealed. └ Gasket gap. </p>	

TROUBLE DIAGNOSIS

CLAIMS.	CAUSES AND CHECK POINTS.	HOW TO CHECK
<p>6. Dew and ice formation.</p>	<p>4) Dew on door.</p> <ul style="list-style-type: none"> - Dew on the duct door. - Duct door heater is cut. - Dew on the dispense recess. <ul style="list-style-type: none"> └ Recess Heater is cut. └ Duct door is open. / Foreign material clogging. - Dew on the door surface. <ul style="list-style-type: none"> └ Not fully filled. <ul style="list-style-type: none"> └ Surface. } Liquid shortage. └ Corner. } Liquid leak. └ P/U liquid contraction. - Dew on the gasket surface. <ul style="list-style-type: none"> └ Bad wing adhesion. <ul style="list-style-type: none"> └ Wing sag(lower part). └ Door liner shape mismatch. └ Corner. <ul style="list-style-type: none"> └ Too much notch. └ Broken. └ Home Bar heater is cut. <p>5) Water on the floor.</p> <ul style="list-style-type: none"> - Dew in the refrigerator compartment. - Defrosted water overflows. — Clogged discharging hose. - Discharging hose — Evaporation tray located at wrong place. location. - Tray drip. <ul style="list-style-type: none"> └ Damaged. └ Breaks, holes. └ Small Capacity. - Position of drain. 	
<p>7. Sounds</p>	<p>1) Compressor compartment operating sounds.</p> <ul style="list-style-type: none"> - Compressor sound inserted. <ul style="list-style-type: none"> └ Sound from machine itself. └ Sound from vibration. <ul style="list-style-type: none"> └ Restrainer. └ Rubber seat. <ul style="list-style-type: none"> └ Too hard. └ Distorted. └ Aged. └ Burnt. └ Stopper. — Bad Stopper assembly. <ul style="list-style-type: none"> └ Not fit (inner diameter of stopper). └ Tilted. └ Not └ Compressor base not connected. └ Bad welding compressor stand(fallen). └ Foreign materials in the compressor compartment. - O.L.P. sound. — Chattering sound. Insulation paper vibration. - Capacitor noise. Pipe sound. <ul style="list-style-type: none"> └ Pipe contacts each other. — Narrow interval. └ No vibration damper. <ul style="list-style-type: none"> └ Damping rubber-Q. └ Damping rubber-S. └ Capillary tube unattached. 	

TROUBLE DIAGNOSIS

CLAIMS.	CAUSES AND CHECK POINTS.	HOW TO CHECK
7. Sounds	<p>1) Compressor compartment operating sounds.</p> <ul style="list-style-type: none"> Transformer sound. <ul style="list-style-type: none"> Its own fault. — Core gap. Bad connection. — Correct screw connection. Drip tray vibration sound. <ul style="list-style-type: none"> Bad assembly. Distortion. Foreign materials inside. Back cover machine sound. <ul style="list-style-type: none"> Bad connection. Partly damaged. Condenser drain sound. <ul style="list-style-type: none"> Not connected. Bad pipe caulking. <p>2) Freezer compartment sounds.</p> <ul style="list-style-type: none"> Fan motor sound. <ul style="list-style-type: none"> Normal operating sound. Vibration sound. <ul style="list-style-type: none"> Aged rubber seat. Bad torque for assembling motor bracket. Sounds from fan contact. <ul style="list-style-type: none"> Fan guide contact. Shroud burr contact. Damping evaporator contact. Residual frost contact. <ul style="list-style-type: none"> Poor treatment Cord heater. Narrow evaporator interval. Unbalance fan sounds. <ul style="list-style-type: none"> Unbalance. <ul style="list-style-type: none"> Surface machining conditions. Fan distortion. Misshappen. Burr. Ice on the fan. — Air intake (opposite to motor rubber assembly) Motor shaft contact sounds. <ul style="list-style-type: none"> Supporter disorted. Tilted during motor assembly. Resonance. Evaporator noise. <ul style="list-style-type: none"> Evaporator pipe contact. — No damping evaporator. Sound from refrigerant. — Stainless steel pipe shape in accumulator. Sound from fin evaporator and pipe during expansion and contraction. <p>3) Bowls and bottles make contact on top shelf.</p> <p>4) Refrigerator roof contact.</p> <p>5) Refrigerator side contact.</p> <p>6) Insufficient Lubricants on door hinge.</p>	

TROUBLE DIAGNOSIS

CLAIMS.	CAUSES AND CHECK POINTS.	HOW TO CHECK
<p>8. Faulty lamp (freezer and refrigerator compartment).</p>	<p>1) Lamp problem. — Filament blows out. — Glass is broken.</p> <p>2) Bad lamp assembly. — Not inserted. — Loosened by vibration.</p> <p>3) Bad lamp socket.</p> <p>— Disconnection. — Bad soldering. — Bad rivet contact.</p> <p>— Short. — Water penetration. — Low water level in tray.</p> <p>— Bad elasticity of contact.</p> <p>— Bad contact (corrosion).</p> <p>4) Door switch. — Its own defect. — Refrigerator and freezer switch is reversed. — Travel distance. — Bad connection. — Bad terminal contact. — P/U liquid leak..</p>	
<p>9. Faulty internal voltage (short).</p>	<p>1) Lead wire is damaged.</p> <p>— Wire damage when assembling P.T.C. Cover. — Outlet burr in the bottom plate. — Pressed by cord heater. lead wire, evaporator pipe.</p> <p>2) Exposed terminal.</p> <p>— Compressor Compartment terminal. - Touching other components. — Freezer compartment terminal. - Touching evaporator pipe.</p> <p>3) Faulty parts.</p> <p>— Transformer. — Coil contacts cover. — Welded terminal parts contact cover.</p> <p>— Compressor. — Bad coil insulation.</p> <p>— Plate heater.</p> <p>— Melting fuse. — Sealing is broken. — Moisture penetration.</p> <p>— Cord heater. — Pipe damaged. — Moisture penetration. — Bad sealing.</p> <p>— Sheath heater.</p>	<p>■ Connect conduction and non-conduction parts and check with tester. Conduction: NG. Resistance∞: OK.</p>

TROUBLE DIAGNOSIS

CLAIMS.	CAUSES AND CHECK POINTS.	HOW TO CHECK
<p>10. Structure, appearance and others.</p>	<p>1) Door foam.</p> <ul style="list-style-type: none"> Sag. <ul style="list-style-type: none"> Weak torque of hinge connection. <ul style="list-style-type: none"> Bolt is loosened during transportaion. Not tightly fastened. Screw worn out . Weak gasket adhesion. <ul style="list-style-type: none"> Adhesion surface. Fixed tape. <ul style="list-style-type: none"> Not well fixed. Noise during operation. <ul style="list-style-type: none"> Hinge interference. <ul style="list-style-type: none"> Bigger door foam. Hinge-Pin tilted-Poor flatness. No washer. No grease and not enough quantity. Malfunction. <ul style="list-style-type: none"> Not closed Interference between door liner and inner liner. Refrigerator compartment is opened when freezer compartment is closed (faulty stopper). <ul style="list-style-type: none"> Stopper worn out. Bad freezer compartment door assembly. No stopper. <p>2) Odor.</p> <ul style="list-style-type: none"> Temperature of refrigerator compartment. <ul style="list-style-type: none"> High. <ul style="list-style-type: none"> Faulty damper control. Button is set at "weak". Door is open (interference by food). Deodorizer. <ul style="list-style-type: none"> No deodorizer. Poor capacity. Food Storage. <ul style="list-style-type: none"> Seal condition. Store special odorous food. Long term storage. Others. <ul style="list-style-type: none"> Odors from chemical products. 	

2. Faults

2-1. Power

Problems	Causes	Checks	Measures	Remarks
No power on outlet.	<ul style="list-style-type: none"> - Power cord cut. - Faulty connector insertion. - Faulty connection between plug and adapter. 	<ul style="list-style-type: none"> - Check the voltage with tester. - Check visually. - Check visually. 	<ul style="list-style-type: none"> - Replace the components. - Reconnect the connecting parts. - Reconnect the connecting parts. 	
Fuse blows out.	<ul style="list-style-type: none"> - Short circuit by wrong connection. - Low voltage products are connected to high voltage. - Short circuit by insects. - Electricity leakage. - High voltage. - Short circuit of components (tracking due to moisture and dust penetration). 	<ul style="list-style-type: none"> - Check the fuse with tester or visually. - Check the input volt are with tester (between power cord and products). - Check the resistance of power cord with testerf (if it is 0Ω, it is shorted). 	<ul style="list-style-type: none"> - Find and remove the cause of problem(ex. short, high voltage, low voltage). - Replace with rated fuse. 	<ul style="list-style-type: none"> - Replace with rated fuse after confirming its specification. ■ If fuse blows out frequently, reconfirm the cause and prevent.

2-2. Compressor

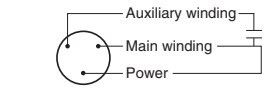
Problems	Causes	Checks	Measures	Remarks
Compressor does not operate.	- Faulty PTC.	<ul style="list-style-type: none"> - Check the resistance. Value:∞ is defective. 	<ul style="list-style-type: none"> - If resistance is infinite, replace it with new one. - If it is not infinite, it is normal. - Check other parts. 	
	- Compressor is frozen.	<ul style="list-style-type: none"> - If compressor assembly parts are normal(capacitor, PTC, OLP), apply power directly to the compressor to force operation.  <p>OLP It starts as soon as it is contacted.</p>	<ul style="list-style-type: none"> - During forced operation: <ul style="list-style-type: none"> - Operates: Check other parts. - Not operate: Replace the frozen compressor with new one, weld, evacuate, and recharge refrigerant. • Refer to weld repair procedures. 	

2-3. Temperature

Problems	Causes	Checks	Measures	Remarks
High temperature in the freezer compartment.	Poor cool air circulation due to faulty fan motor.	<ul style="list-style-type: none"> - Lock — Check resistance with a tester. 0Ω: short. ∞Ω: cut. - Rotate rotor manually and check rotation. - Wire is cut. - Bad terminal contact: Check terminal visually. - Fan constraint. – Fan shroud contact: Confirm visually. – Fan icing: Confirm visually. 	<ul style="list-style-type: none"> - Replace fan motor. - Reconnect and reinsert. - Maintain clearance and remove ice (Repair and/or replace shroud if fan is constrained by shroud deformation). 	
	Faulty fan motor due to faulty door switch operation.	<ul style="list-style-type: none"> - Iced button (faulty) operation: Press button to check - Faulty button pressure and contact: Press button to check operation. - Door cannot press door switch button: Check visually. 	<ul style="list-style-type: none"> - Confirm icing causes and repair. - Replace door switch. - Door sag: fix door. - Door liner bent: replace door or attach sheets. 	
	Bad radiation conditions in compressor compartment.	<ul style="list-style-type: none"> - Check the clearance between the refrigerator and wall (50 mm in minimum). - Check dust on the grill in compressor compartment. - Check dust on the coils condenser. 	<ul style="list-style-type: none"> - Keep clearance between refrigerator and walls (minimum 50mm). - Remove dust and contaminants from grill for easy heat radiation. - Remove the dust with vacuum cleaner from the coils condenser while the refrigerator is off. 	<ul style="list-style-type: none"> - The fan may be broken if cleaning performs while the refrigerator is on.

2-4. Cooling

Problems	Causes	Checks	Measures	Remarks
High temperature in the freezer compartment.	Refrigerant leak.	<u>Check sequence</u> 1. Check the welded parts of the drier inlet and outlet and drier auxiliary in the compressor compartment (high pressure side). 2. Check the end of compressor sealing pipe (low pressure side). 3. Check silver soldered parts. (Cu + Fe / Fe + Fe). 4. Check bending area of wire condenser pipe in compressor compartment (cracks can happen during bending). 5. Check other parts (compressor compartment and evaporators in freezer compartment).	Weld the leaking part, recharge the refrigerant.	Drier must be replaced.
	Shortage of refrigerant.	Check frost formation on the surface of evaporator in the freezer compartment. - If the frost forms evenly on the surface, it is OK. - If it does not, it is not good.	- Find out the leaking area, repair, evacuate, and recharge the refrigerant. - No leaking, remove the remaining refrigerant, and recharge new refrigerant.	Drier must be replaced.

Problems	Causes	Checks	Measures	Remarks
High temperature in the freezer compartment.	Cycle pipe is clogged.	<p>Check sequence.</p> <p>1. Check temperature of condenser manually. If it is warm, it is OK. If it is not, compressor discharging joints might be clogged.</p> <p>2. Manually check whether hot line pipe is warm. If it is warm, it's OK. If it is not, condenser outlet weld joints might be colgged.</p>	<p>- Heat up compressor discharging weld joints with touch, disconnect the pipes, and check the clogging. Remove the causes of clogging, weld, evacuate, and recharge the refrigerant.</p> <p>- If it's warm, it's OK. If it's not, condenser discharging line weld joints might be clogged. Disconnect with torch, remove the causes, evacuate, and recharge seal refrigerant.</p>	Direr must be replaced.
	Leak at loop pipe weld joint (discharge) in compressor.	<p>Check sequence.</p> <p>1. Manually check whether condenser is warm, It is not warm and the frost forms partly on the evaporator in the freezer compartment.</p>	Replace the compressor, weld, evacuate, and recharge refrigerant.	Drier must be replaced.
	Faulty cooling fan in the compressor compartment.	<p>Check sequence.</p> <p>1. Check cooling fan operation. 2. Check that cooling fan is disconnected from the motor.</p>	<p>- Replace if motor does not operate.</p> <p>- If fan is disconnected, check fan damage and reassemble it.</p> <p>■ Refer to fan motor disassembly and assembly sequence.</p>	

2-5. Defrosting failure

Problems	Causes	Checks	Measures	Remarks
No defrosting.	<p>Heater does not generate heat as the heating wire is cut or the circuit is shorted.</p> <p>1) Heating wire is damaged when inserting into the evaporator. 2) Lead wire of heater is cut. 3) Heating wire at lead wire contacts is cut.</p>	<p>1. Check the resistance of heater. 0Ω: Short. ∞Ω: Cut. Tens to thousands Ω: OK.</p> <p>2. Check the resistance between housing terminal and heater surface. 0Ω: Short. ∞Ω: Cut. Tens to thousands Ω: Short.</p>	<p>Heating wire is short and wire is cut.</p> <p>• Parts replacement: Refer to parts explanations.</p>	<p>Seal the lead wire with insulation tape and heat contraction tube if the cut lead wire is accessible to repair.</p>
	<p>Sucking duct and discharging hole are clogged:</p> <p>1. Impurities. 2. Ice.</p>	<p>1. Confirm foreign materials. In case of ice, insert the copper line through the hole to check. 2. Put hot water into the drain (check drains outside).</p>	<p>1) Push out impurities by inserting copper wire.(Turn off more than 3hours and pour in hot water if frost is severe.) 2) Put in hot water to melt down frost. 3) Check the water outlet. 4) Push the heater plate to sucking duct manually and assemble the disconnected parts.</p>	
	<p>Gap between Sucking duct and Heater plate(Ice in the gap).</p>	<p>1. Confirm in the Sucking duct.</p>	<p>1) Turn off the power, confirm impurities and ice in the gap, and supply hot water until the ice in the gap melts down. 2) Push the Heater plate to drain bottom with hand and assemble the disconnected parts.</p>	
	<p>Wrong heater rating (or wrong assembly).</p>	<p>1. Check heater label. 2. Confirm the capacity after substituting the resistance value into the formula.</p> $P = \frac{V^2}{R}$ <p>(V: Rated voltage of user country) (R: Resistance of tester(Ω)) Compare P and level capacity. Tolerance: ±7%</p>	<p>Faults:replace. - How to replace: Refer to main parts.</p>	

Problems	Causes	Checks	Measures	Remarks
No defrosting	Melting fuse blows out. 1) Lead wire is cut. 2) Bad soldering.	- Check melting fuse with tester. - If 0Ω: OK. If ∞Ω: wire is cut.	Faulty parts: parts replacement. - Check wire color when measuring resistance with a tester.	
	Ice in the Sucking duct. 1) Icing by foreign materials in the duct. 2) Icing by cool air inflow through the gap of heater plate. 3) Icing by the gap of heater plate.	1. Check the inner duct with mirror. 2. Check by inserting soft copper wire into the duct (soft and thin copper not to impair heating wire).	1) Turn power off. 2) Raise the front side(door side), support the front side legs, and let the ice melt naturally. (If power is on, melt the frost by forced defrosting.) 3) Reassemble the heater plate.	
	Bad cool air inflow and discharge, and bad defrosting due to faulty contact and insertion (bad connector insertion into housing of heater, melting, fuse and motor fan).	1. Turn on power, open or close the door, check that motor fan operates (If it operates, motor fan is OK). 2. Disconnect parts in the refrigerator compartment, check the connection around the housing visually, defrost, and confirm heat generation on the heater. Do not put hands on the sheath heater. 3. Check the parts which have faults described in 1, 2 (mechanical model: disconnect thermostat from the assembly).	1) Check the faulty connector of housing and reassemble wrongly assembled parts. 2) If the parts are very damaged, remove the parts and replace it with a new one.	

2-6. Icing

Problems	Causes	Checks	Measures	Remarks
Icing in the refrigerator compartment. - Damper icing. - Pipe icing. - Discharging pipe icing.	1) Bad circulation of cool air. - Clogged intake port in the refrigerator compartment. - Sealing is not good. - Too much food is stored and clogs the discharge port. - Bad defrosting.	- Check the food is stored properly (check discharge and intake port are clogged). - Check icing on the surface of baffle and cool air path (pipe) after dissembling the container box. - Check icing at intake ports of freezer and refrigerator compartment.	- Be acquainted with how to use. - Sealing on connecting parts. - Check the damper and replace it if it has defects. - Check defrost. (After forced defrosting, check ice in the evaporator and pipes.)	- Check the defrost related parts if problem is caused by faulty defrosting.
	2) Faulty door or refrigerator compartment. - Faulty gasket. - Faulty assembly.	- Check gasket attached conditions. - Check door assembly conditions.	- Correct the gasket attachment conditions and replace it. - Door assembly and replacement.	- Replacement should be done when it cannot be repaired.
	3) Overcooling in the refrigerator compartment. - Faulty damper in the refrigerator compartment. - Faulty MICOM (faulty sensor)	- Check refrigerator compartment is overcooled (when button pressed on "weak"). - Check parts are faulty.	- Replace faulty parts.	
	4) Bad defrosting - Heater wire is cut. - Defective defrost sensor. - Defrozing cycle.	- Check frost on the evaporator after dissembling shroud and fan grille. - Check ice on intake port of freezer and refrigerator compartment.	- Check parts related to defrosting. - Check defrosting. (Check ice on the evaporator and pipe.)	- Moisture cannot frost on the evaporator but can be sucked into the refrigerator, being condensed and iced, interferes with cool air circulation, and suppresses sublimation.
	5) Customers are not familiar with this machine. - Door opens. - High temperature, high moisture, and high load.	- Check food interferes with door closing. - Check ice on the ceilings.	- Be acquainted with how to use.	

Problems	Causes	Checks	Measures	Remarks
Ice in the freezer compartment. - Surface of fan grille. - Wall of freezer compartment. - Cool air discharging port. - Basket(rack) area. - Food surface. - Icing in the shute.	1) Bad cooling air circulation. - Intake port is colgged in the freezer compartment. - Discharging port is Clogged. - Too much food is stored. - Bad defrosting.	- Check food storage conditions visually.(Check clogging at intake and discharging port of cooling air.) - Check food occupation ratio in volume(Less than 75%). - Check frost on the evaporator after dissembling shroud and fan grille. - Check icing at intake port of refrigerator compartment.	- Be acquainted with how to use. - Check defrost (Check ice on the evaporator and pipes after forced defrosting).	- Check the parts related to defrosting if the problem is caused by the faulty defrosting.
	2) Bad freezer compartment door - Faulty gasket - Faulty assembly	- Check gasket attachment conditions. - Check door assembly conditions.	- Correct the gasket attachment conditions and replace it. - Door assembly and replacement.	- Replace when it can not be repaired.
	3) Over freezing in the freezer compartment. - Faulty MICOM.	- Refrigerator operates pull down. (Check if it is operated intermittently) - The Temperature of freezer compartment is satisfactory, but over freezing happens in the refrigerator compartment even though the notch is set at "weak".	-Replace defective parts.	
	4) Bad defrosting. - Heater wire is cut. - Faulty defrost sensor. - Defrosting cycle	- Check frost on the evaporator after dissembling shroud and grille. - Check ice on the intake port in the refrigerator compartment.	- Check parts related to defrosting. - Check defrosting.(Check ice on the evaporator and pipes after forced defrosting.)	
	5) User is not familiar with how to use. - Door opens. - High moisture food(water) is stored.	- Check food holds door open. - Check ice on the ice tray.	- Be acquainted with how to use.	

2-7. Sound

Problems	Causes	Checks	Measures	Remarks
"Whizz" sound	1. Loud sound of compressor operation.	1.1 Check the level of the refrigerator. 1.2 Check the rubber seat conditions (sagging and aging).	1) Maintain horizontal level. 2) Replace rubber and seat if they are sagged and aged. 3) Insert rubber where hand contact reduces noise in the pipe. 4) Avoid pipe interference. 5) Replace defective fan and fan motor. 6) Adjust fan to be in the center of bell mouth of the fan guide. 7) Leave a clearance between interfering parts and seal gaps in the structures. 8) Reassemble the parts which make sound. 9) Leave a clearance if evaporator pipes and suction pipe touch freezer shroud.	
	2. Pipes resonat sound which is connected to the compressor.	2.1 Check the level of pipes connected to the compressor and their interference. 2.2 Check rubber inserting conditions in pipes. 2.3 Touch pipes with hands or screw -driver (check the change of sound).		
	3. Fan operation sound in the freezer compartment.	3.1 Check fan insertion depth and blade damage. 3.2 Check the interference with structures. 3.3 Check fan motor. 3.4 Check fan motor rubber insertion and aging conditions.		
	4. Fan operation sound in the compressor compartment.	4.1 Same as fan confirmation in the refrigerator. 4.2 Check drip tray leg insertion. 4.3 Check the screw fastening conditions at condenser and drip tray.		

Problems	Causes	Checks	Measures	Remarks
Vibration sound. ("Cluck")	<ol style="list-style-type: none"> 1. Vibration of shelves and foods in the refrigerator. 2. Pipes interference and capillary tube touching in the compressor compartment. 3. Compressor stopper vibration. 4. Moving wheel vibration. 5. Other structure and parts vibration. 	<ol style="list-style-type: none"> 1-1. Remove and replace the shelves in the refrigerator 1-2. Check light food and container on the shelves. 2-1. Touch pipes in the compressor compartment with hands. 2-2 Check capillary tube touches cover back. 3-1 Check compressor stopper vibration. 4-1 Check vibration of front and rear moving wheels. 5-1 Touch other structures and parts. 	<ol style="list-style-type: none"> 1) Reassemble the vibrating parts and insert foam or cushion where vibration is severe. 2) Leave a clearance where parts interfere with each other. 3) Reduce vibration with rubber and restrainer if it is severe. (especially, compressor and pipe). 4) Replace compressor stopper if it vibrates severely. 	
Irregular sound. ("Click").	<ol style="list-style-type: none"> 1. It is caused by heat expansion and contraction of evaporator, shelves, and pipes in the refrigerator. 	<ol style="list-style-type: none"> 1-1 Check time and place of sound sources. 	<ol style="list-style-type: none"> 1) Explain the principles of refrigeration and that the temperature difference between operation and defrosting can make sounds. 2) If evaporator pipe contacts with other structures, leave a clearance between them (freezer shroud or inner case). 	

Problems	Causes	Checks	Measures	Remarks
Sound "Burping" (almost the same as animals crying sound).	It happens when refrigerant expands at the end of capillary tube.	<ul style="list-style-type: none"> - Check the sound of refrigerant at the initial installation. - Check the sound when the refrigerator starts operation after forced defrosting. - Check the restrainer attachment conditions on the evaporator and capillary tube weld joints. 	<ul style="list-style-type: none"> - Check the restrainer attached on the evaporator and capillary tube weld joints and attach another restrainer. - If it is continuous and severe, insert capillary tube again (depth: 15±3mm) - Fasten the capillary tube to suction pipes or detach in the compressor compartment. - Explain the principles of freezing cycles. 	
Water boiling or flowing sound.	It happens when refrigerant passes orifice in accumulator internal pipes by the pressure difference between condenser and evaporator.	<ul style="list-style-type: none"> - Check the sound when compressor is turned on. - Check the sound when compressor is turned off. 	<ul style="list-style-type: none"> - Explain the principles of freezing cycles and refrigerant flowing phenomenon by internal pressure difference. - If sound is severe, wrap the accumulator with foam and restrainer. 	
Sound of whistle when door closes.	When door closes, the internal pressure of the refrigerator decreases sharply below atmosphere and sucks air into the refrigerator, making the whistle sound.	<ul style="list-style-type: none"> - Check the sound by opening and closing the refrigerator or freezer doors. 	<ul style="list-style-type: none"> - Broaden the cap of discharge hose for defrosting in the compressor compartment. - Seal the gap with sealant between out and inner cases of hinge in door. 	

2-8. Odor

Problems	Causes	Checks	Measures	Remarks
Food Odor.	Food (garlic, kimchi, etc)	<ul style="list-style-type: none"> - Check the food is not wrapped. - Check the shelves or inner wall are stained with food juice. - Check the food in the vinyl wraps. - Check food cleanliness. 	<ul style="list-style-type: none"> - Dry deodorizer in the shiny and windy place. - Store the food in the closed container instead of vinyl wraps. - Clean the refrigerator and set button at "strong". 	
Plastic Odor.	Odors of mixed food and plastic odors.	<ul style="list-style-type: none"> - Check wet food is wrapped with plastic bowl and bag. - It happens in the new refrigerator. 	<ul style="list-style-type: none"> - Clean the refrigerator. - Persuade customers not to use plastic bag or wraps with wet food or odorous foods. 	
Odor from the deodorizer.	Odor from the old deodorizer.	<ul style="list-style-type: none"> - Check the deodorizer odors. 	<ul style="list-style-type: none"> - Dry the deodorizer with dryer and then in the shiny and windy place. - Remove and replace the deodorants. 	*Deodorizer : option

2-9. Micom

Problems	Symptom	Causes		Checks	Measures	Remarks			
Bad PCB electric power.	All display LCD are off.	Bad connection between Main PCB and display circuit.	Bad connector connection from main PCB to display PCB.	Visual check on connector connection.	Reconnect connector.				
		Defective PCB trans.	PCB Trans winding is cut.	Check resistance of PCB Trans input and output terminals with a tester. (If resistance is infinity, trans winding is cut).	Replace PCB Trans or PCB.	Applicable to model without dispenser.			
			PCB Trans temperature fuse is burnt out.						
		Defective PCB electric circuit parts.	Defective regulator IC (7812, 7805).	Check voltage at input/output terminals.	Replace regulator.	Refer to electric circuit in circuit explanation.			
							PCB electric terminal fuse is burnt out.	Check fuse in PCB electric terminal with a tester.	Replace PCB fuse.
							STR Parts are damaged.	Check if STR No. 2 and 3 pins are cut when power is off.	Replace parts.
Abnormal display LCD operation	Bad connection between Main PCB and display circuit.	Lead Wire connecting main PCB and display PCB is cut or connector terminal connection is bad.	Check Lead Wire terminals connecting Main PCB and display PCB with a tester.	Reconnect Lead Wire and directly connect defective contact terminal to Lead Wire.					
	Defective LCD.	Defective LCD.	Check if all LCD are on when Main PCB Test switch is pressed (or when both freezer key and power freezer key are pressed at the same time for more than one second.)	Replace display PCB.	Refer to display circuit in circuit explanation.				

Problems	Symptom	Causes		Checks	Measures	Remarks
Bad cooling.	Freezer temperature is high.	Compressor does not start.	Compressor Lead Wire is cut.	Check compressor Lead Wire with a tester.	Reconnect Lead Wire.	
			Defective compressor driving relay.	Measure voltage at PCB CON2 (3&9) after pressing main PCB test switch once. It is OK if voltage is normal.	Replace relay(RY1 and RY2) or PCB.	Refer to load driving circuit in circuit explanation.
		Defective freezer sensor.	Defective Freezer sensor parts.	Check resistance of freezer sensor with a tester.	Replace freezer sensor.	Refer to resistance characteristics table of sensor in circuit explanation.
			Freezer sensor is substituted for other sensor.	Confirm the color of sensor in circuits (main PCB sensor housing).	Repair main PCB sensor housing	
		Defective freezer fan motor.	Fan motor lead wire is cut.	Check fan motor lead wire with a tester.	Reconnect lead wire.	
			<ul style="list-style-type: none"> • Defective door switch (freezer, refrigerator, home bar). • Defective fan motor. • Defective fan motor driving relay. 	Measure the voltage between PCB power blue line and fan motor after pressing test switch of Main PCB. If the voltage is normal, it is OK.	<ul style="list-style-type: none"> • Replace door switch (freezer, refrigerator and home bar). • Replace fan motor. 	Refer to load driving circuits in circuit explanation.
		Faulty defrost.		Refer to faulty defrost items in trouble diagnosis functions.		Refer to trouble diagnosis function.

Problems	Symptom	Causes		Checks	Measures	Remarks
Bad cooling	Wrong Refrigerator temperature.	Defective Step Motor Damper.	Check Step Motor damper motor and reed switch and lead wire are cut. Check Step Motor damper part.	Check if Step Motor damper motor and reed switch lead wire are cut with a tester.	Reconnect lead wire.	
				Refer to Step Motor damper in parts repair guide.	Replace Step Motor damper or refrigerator control box Assembly.	
			Check Step Motor damper Motor driving relay in PCB.	Refer to Step Motor damper in parts repair guide.	Replace relay or PCB.	Refer to single motor damper driving circuits in circuit explanation.
			Foreign materials in Step Motor damper baffles.	Check Step Motor damper baffle visually.	Remove foreign materials.	
			Ice formation on Step Motor damper baffles.	Check if Step Motor damper Heater wire is cut with a tester.	Replace Step Motor damper or refrigerator control Box Assembly.	
		Defective refrigerator sensor	Defective refrigerator sensor parts.	Check the resistance of refrigerator sensor with a tester.	Replace refrigerator sensor.	Refer to sensor resistance characteristic table in circuit explanation.
			Refrigerator sensor is substituted for other sensor.	Check the sensor color in the circuit. (main PCB sensor housing.)	Repair main PCB sensor housing.	
			Defective refrigerator sensor assembly condition.	Check if refrigerator sensor is not fixed at cover sensor but inner case visually.	Fix again the refrigerator sensor.	

Problems	Symptom	Causes	Checks	Measures	Remarks
Bad defrost.	Defrost is not working.	Defrost lead wire is cut.	Check if defrost lead wire is cut with a tester.	Reconnect Lead Wire.	
		Defective defrost driving relay.	Check the voltage of CON2 (1 and 7) with a tester after pressing main PCB test switch twice. If the voltage is normal then it is OK.	Replace relay (RY 7 and RY 3) or PCB.	Refer to load driving conditions check in circuit explanation.
		Defective defrost sensor parts.	Check the resistance of defrost sensor with a tester.	Replace defrost sensor.	Refer to sensor resistance characteristic table of circuit explanation.
Defective buzzer	Buzzer continuously rings or door opening alarm does not work.	Defective connecting lead wire from main PCB to door switch.	Check lead wire related to door switch with a tester.	Repair lead wire.	
		Defective door switch parts.	Refer to door switch in parts repair guide.	Replace door switch.	
Defective display button	Buzzer does not ring and key does not sense even button is pressed.	Key input wire is cut or bad connector terminal contact in main PCB and display PCB connecting lead wire.	Check input wire with a tester.	Reconnect lead wire and replace or directly connect bad contact terminal to lead wire.	Refer to display circuit in circuit explanation.
		Key is continuously depressed due to structural interference.	Disassemble frame display and confirm visually.	Adjust or replace interfering structures.	

Problems	Symptom	Causes	Checks	Measures	Remarks
Defective display button.	Buzzer rings but key does not sense even button is pressed.	Trouble mode indication.	Check trouble diagnosis function.	Repair troubles	Refer to mode indication in function explanations.
Door Buzzer	Buzzer continuously rings or door opening alarm does not work.	Defective connecting lead wire from main PCB to door switch.	Check lead wire associated with door switch.	Repair lead wire.	Check model with dispenser.
		Defective freezer compartment door switch parts.	Refer to door switch in parts repair guide.	Replace Freezer compartment door switch.	
Bad water/ice dispenser.	Ice and water are not dispensed.	Defective connecting lead wire from Main PCB to lever switch.	Check Lead Wire associated with lever switch with a tester.	Repair lead wire.	
		Defective lever switch parts	Refer to door switch in parts repair guide.	Replace lever switch.	
		Defective photo coupler IC parts.	Check voltage change at photo coupler output terminals with lever switch pressed. It is OK if voltage change is between 0V - 5V.	Replace photo coupler IC or PCB.	
		Defective relay associated with ice dispense (geared motor, cube and dispenser solenoid).	Check relay (RY4, RY5, RY12) with a tester.	Replace defective relay.	
		Defective parts associated with ice dispense (geared motor, cube and dispenser solenoid).	Check resistance of parts with a tester.	Replace defective parts.	
		Defective relay associated with water dispense.	Check relay (RY7) with a tester	Replace defective relay.	
		Defective parts associated with water dispenser.	Check resistance of parts with a tester.	Replace defective parts.	

TROUBLE DIAGNOSIS

3. Cooling Cycle Heavy Repair







3-1. The Heavy Repair Standards for Refrigerator with R134a Refrigerant

NO.	Items	Unit	Standards	Purposes	Remarks	
1	Pipe and piping system opening time.	Min.	Pipe:within 1 hour. Comp:within 10 minutes. Drier:within 20 minutes.	To protect Moisture Penetration.	The opening time should be reduced to a half of the standards during rain and rainy seasons (the penetration of water into the pipe is dangerous).	
2	Welding.	Nitrogen Pressure.	Weld under Nitrogen atmosphere (N ₂ pressure: 0.1~0.2 kg/cm ²)	To protect oxide scale formation.	- Refet to repair note in each part. - R134a refrigerant is more susceptible to leaks than R12 and requires more care during welding. - Do not apply force to pipes before and after welding to protect pipe from cracking.	
3	N ₂ sealed parts.	Confirm N ₂ leak.	Confirm air leaking sounds when removing rubber cap. Sound:usable No sound:not usable	To protect moisture penetration.	- In case of evaporator parts, if it doesn't noise when removing rubber cap blow dry air or N ₂ gas for more than 1 min use the parts.	
4	Refrigeration Cycle.	Evacuation time	Min.	More than 40 minutes.	To remove moisture.	Note:Only applicable to the model equipped with reverse flow protect plate. Vaccum efficiency can be improved by operating compressor during evacuation. The rubber pipes for R12 refrigerant shall be melted when they are used for R134a refrigerant(causes of leak).
		Vacuum degree	Torr	Below 0.03(ref)		
		Vacuum	EA	High and low Pressure sides are evacuated at the same time for models above 200ℓ		
		Vacuum piping	EA	Use R134a exclusive manifold.	To protect mixing of mineral and ester oils.	
		Pipe coupler	EA	Use R134a cxclusive.	To protect R12 Refrigerant mixing.	
		Outlet (Socket) Plug		R134a exclusive. R134a exclusive		
5	Refrigerant weighing.	EA	Use R134a exclusively. Weighing allowance:±5g Note:Winter:-5g Summer:+5g	Do not mix with R12 refrigerant.	- Do not weight the refrigerant at too hot or too cold an area.(25°C is adequate.) - Use copper bombe Socket:2SV Plug: 2PV R134a Note:Do not burn O-ring (rubber) during welding.	
6	Drier replacement.		-Use R134a exclusively for R134a refrigerator -Use R12 exclusively for R12 refrigerator -Replace drier whenever repairing refrigerator cycle piping.	To remove the moisture from pipe.		
7	Leak check.		-Do not use soapy water for check. it may be sucked into the pipe by.	Detect refrigerant leak area.	-Check oil leak at refrigerant leak area. Use electronic leak detector if oil leak is not found. -The electronic leak detector is very sensitive to halogen gas in the air. It also can detect R141b in urethane. Please practice, therefore, many times before use.	

NOTE) Please contact Songso company on +82-53-554-2067 if you have inquiry on heavy repair special facility.

TROUBLE DIAGNOSIS

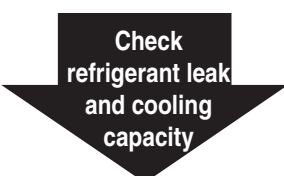
3-2. Summary Of Heavy Repair

Process	Contents	Tools
		
	- Cut charging pipe ends and discharge refrigerant from drier and compressor.	Filter, side cutters
	- Use R134a oil and refrigerant for compressor and drier - Confirm N ₂ sealing and packing conditions before use. Use good one for welding and assembly. - Weld under nitrogen gas atmosphere.(N ₂ gas pressure: 0.1-0.2kg/cm ²). - Repair in a clean and dry place.	Pipe Cutter, Gas welder, N ₂ gas
	- Evacuate for more than forty minutes after connecting manifold gauge hose and vacuum pump to high (drier) and low (compressor refrigerant discharging parts) pressure sides. - Evacuation Speed:113//min.	Vacuum pump(R134a exclusively), Manifold gauge.
	- Weigh and control the allowance of R134a bombe in a vacuum conditions to be ± 5 g with electronic scales and charge through compressor inlet (Charge while refrigerator operates). - Weld carefully after inlet pinching.	R134a exclusive bombe(mass cylinder), refrigerant(R134a) manifold gauge, electronic scales, punching off flier, gas welding machine
	- Check leak at weld joints. ┌ Minute leak: Use electronic leak detector └ Big leak: Check visually or fingers. Note:Do not use soapy water for check. - Check cooling capacity ① Check radiator manually to see if warm. ② Check hot line pipe manually to see if warm. ③ Check frost formation on the whole surface of the evaporator.	Electronic Leak Detector, Driver(Ruler).
	- Remove flux from the silver weld joints with soft brush or wet rag.(Flux may be the cause of corrosion and leaks.) - Clean R134a exclusive tools and store them in a clean tool box or in their place.	Copper brush, Rag, Tool box
	- Installation should be conducted in accordance with the standard installation procedure.(Leave space of more than 5 cm from the wall for compressor compartment cooling fan mounted model.)	

TROUBLE DIAGNOSIS

3-3. Precautions During Heavy Repair

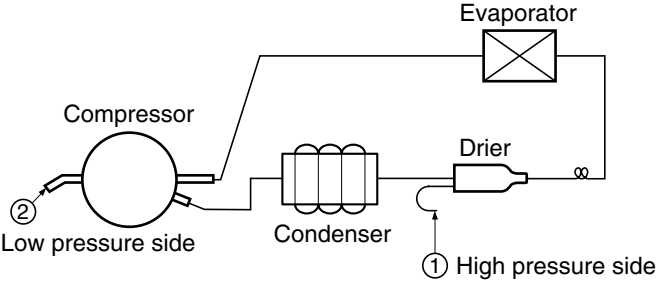
Items	Precautions
1. Use of tools.	1) Use special parts and tools for R134a.
2. Removal of retained refrigerant.	1) Remove retained refrigerant more than 5 minutes after turning off a refrigerator. (If not, oil will leak inside.) 2) Remove retained refrigerant by cutting first high pressure side (drier part) with a nipper and then cut low pressure side. (If the order is not observed, oil leak will happen.) <div style="text-align: center; margin-top: 10px;">  <p>The diagram illustrates a refrigeration cycle with the following components and connections:</p> <ul style="list-style-type: none"> Compressor: Located on the left, with a 'Low pressure side' label and a circled '2' indicating a service point. Condenser: A coil-shaped component connected to the compressor. Drier: A cylindrical component connected to the condenser. A circled '1' indicates the high pressure side at this location. Evaporator: A rectangular component with an 'X' inside, connected to the drier. </div>
3. Replacement of drier.	1) Be sure to replace drier with R134a only when repairing pipes and injecting refrigerant.
4. Nitrogen blowing welding.	1) Weld under nitrogen atmosphere in order to prevent oxidation inside a pipe. (Nitrogen pressure : 0.1~0.2 kg/cm ² .)
5. Others.	1) Nitrogen or refrigerant R134a only should be used when cleaning inside of cycle pipes inside and sealing. 2) Check leakage with an electronic leakage tester. 3) Be sure to use a pipe cutter when cutting pipes. 4) Be careful not the water let intrude into the inside of the cycle.

TROUBLE DIAGNOSIS

3-4. Practical Work For Heavy Repair

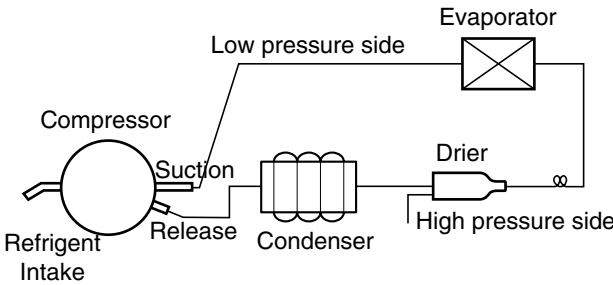
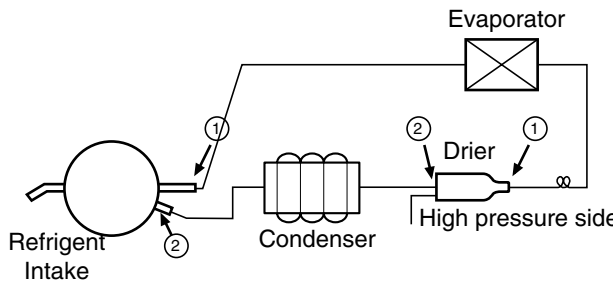
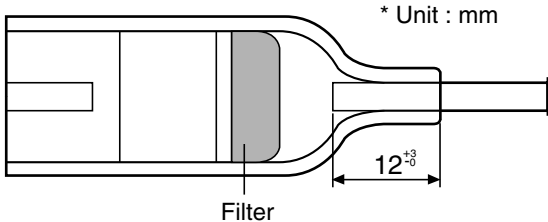
Items	Precautions
<p>1. Removal of residual refrigerant.</p>	<div style="display: flex; justify-content: space-between;"> <div style="width: 60%;">  <p>1) Remove residual refrigerant more than 5 minutes later after turning off the refrigerator. (If not, compressor oil may leak inside.)</p> <p>2) Remove retained refrigerant slowly by cutting first high pressure side (drier part) with a nipper and then cut low pressure side.</p> </div> <div style="width: 35%; border-left: 1px solid black; padding-left: 10px;"> <p>KEYPOINTING</p> <p>Observe the sequence for removal of refrigerant. (If not, compressor oil may leak.)</p> </div> </div>
<p>2. Nitrogen blowing welding.</p>	<div style="display: flex; justify-content: space-between;"> <div style="width: 60%;">  <p>When replacing a drier: Weld ① and ② parts by blowing nitrogen(0.1~0.2kg/cm²) to high pressure side after assembling a drier.</p> <p>When replacing a compressor: Weld ① and ② parts by blowing nitrogen to the low pressure side.</p> <p>Note) For other parts, nitrogen blowing is not necessary because it does not produce oxidized scales inside pipe because of its short welding time.</p> </div> <div style="width: 35%; border-left: 1px solid black; padding-left: 10px;"> <p>KEYPOINTING</p> <p>Welding without nitrogen blowing produces oxidized scales inside a pipe, which affect on performance and reliability of a product.</p> </div> </div>
<p>3. Replacement of drier.</p>	<div style="display: flex; justify-content: space-between;"> <div style="width: 60%;">  <p>Inserting a capillary tube</p> <p>Measure distance with a ruler and put a mark(12^{+3/-0})on the capillary tube. Insert tube to the mark, and weld it</p> </div> <div style="width: 35%; border-left: 1px solid black; padding-left: 10px;"> <p>KEYPOINTING</p> <p>Be sure to check the inserted length of capillary tube when it is inserted. (If too much inserted, a capillary tube is clogged by a filter.)</p> </div> </div>

TROUBLE DIAGNOSIS

Items	Precautions
<p>4. Vacuum degassing.</p>	<div data-bbox="630 367 1380 966" data-label="Diagram"> </div> <p>Pipe Connection Connect a red hose to the high pressure side and a blue hose to the low pressure side.</p> <p>Vacuum Sequence Open ①, ② valves and evacuate for 40 minutes. Close valve ①.</p> <p>KEYPOINTING</p> <ul style="list-style-type: none"> - If power is applied during vacuum degassing, vacuum degassing shall be more effective. - Operate compressor while charging refrigerant. (It is easier and more certain to do like this.)
<p>5. Refrigerant charging.</p>	<p>Charging sequence</p> <ol style="list-style-type: none"> 1) Check the amount of refrigerant supplied to each model after completing vacuum degassing. 2) Evacuate bombe with a vacuum pump. 3) Measure the amount of refrigerant charged. <ul style="list-style-type: none"> - Measure the weight of an evacuated bombe with an electronic scale. - Charge refrigerant into a bombe and measure the weight. Calculate the weight of refrigerant charged into the bombe by subtracting the weight of an evacuated bombe. <div data-bbox="483 1654 820 1984" data-label="Diagram"> </div> <p>KEYPOINTING</p> <ul style="list-style-type: none"> - Be sure to charge the refrigerant at around 25°C. - Be sure to keep -5g in the winter and +5g in summer <div data-bbox="893 1869 1429 1911" data-label="Text" style="border: 1px solid black; padding: 2px;"> <p>Calculation of amount of refrigerant charged</p> </div> <p>the amount of refrigerant charged= a weight after charging - a weight before charging (a weight of an evacuated cylinder)</p>

TROUBLE DIAGNOSIS

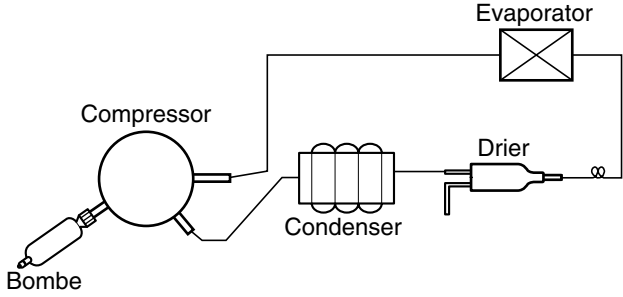
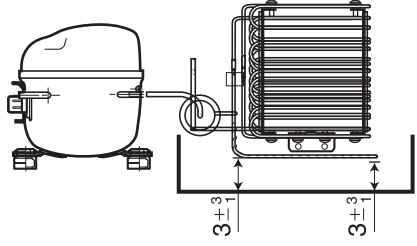
Items	Precautions
	 <p>4) Refrigerant Charging Charge refrigerant while operating a compressor as shown above.</p> <p>5) Pinch a charging pipe with a pinch-off plier after completion of charging.</p> <p>6) Braze the end of a pinched charging pipe with copper brazer and take a gas leakage test on the welded parts.</p>
6. Gas-leakage test	* Take a leakage test on the welded or suspicious area with an electronic leakage tester.
7. Pipe arrangement in each cycle	<p>Check each pipe is placed in its original place before closing a cover back-M/C after completion of work. Particularly control the size of Joint Drain Pipe</p> 

3-5. Standard Regulations For Heavy Repair

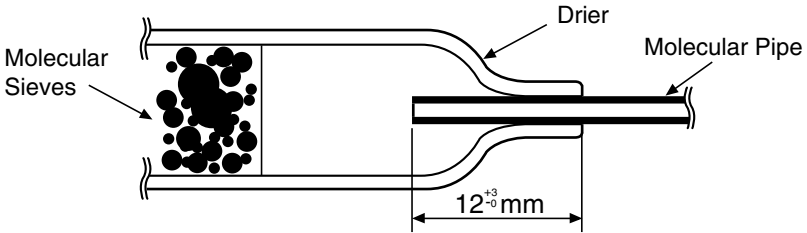
<ol style="list-style-type: none"> 1) Observe the safety precautions for gas handling. 2) Use JIG (or wet towel) in order to prevent electric wires from burning during welding. (In order to prevent insulation break and accident.) 3) The inner case shall be melted and insulation material (polyurethane) shall be burnt if not cared during welding inner case parts. 4) The copper pipe shall be oxidized by overheating if not cared during welding. 5) Not allow the aluminum pipes to contact to copper pipes. (In order to prevent corrosion.) 6) Observe that the inserted length of a capillary tube into a drier should be 12^{+3} mm. 	
<ol style="list-style-type: none"> 7) Make sure that the inner diameter should not be distorted while cutting a capillary tube. 8) Be sure that a suction pipe and a filling tube should not be substituted each other during welding. (High efficiency pump.) 	

TROUBLE DIAGNOSIS

3-6. Brazing Reference Drawings

1) Asia / Middle-East Africa

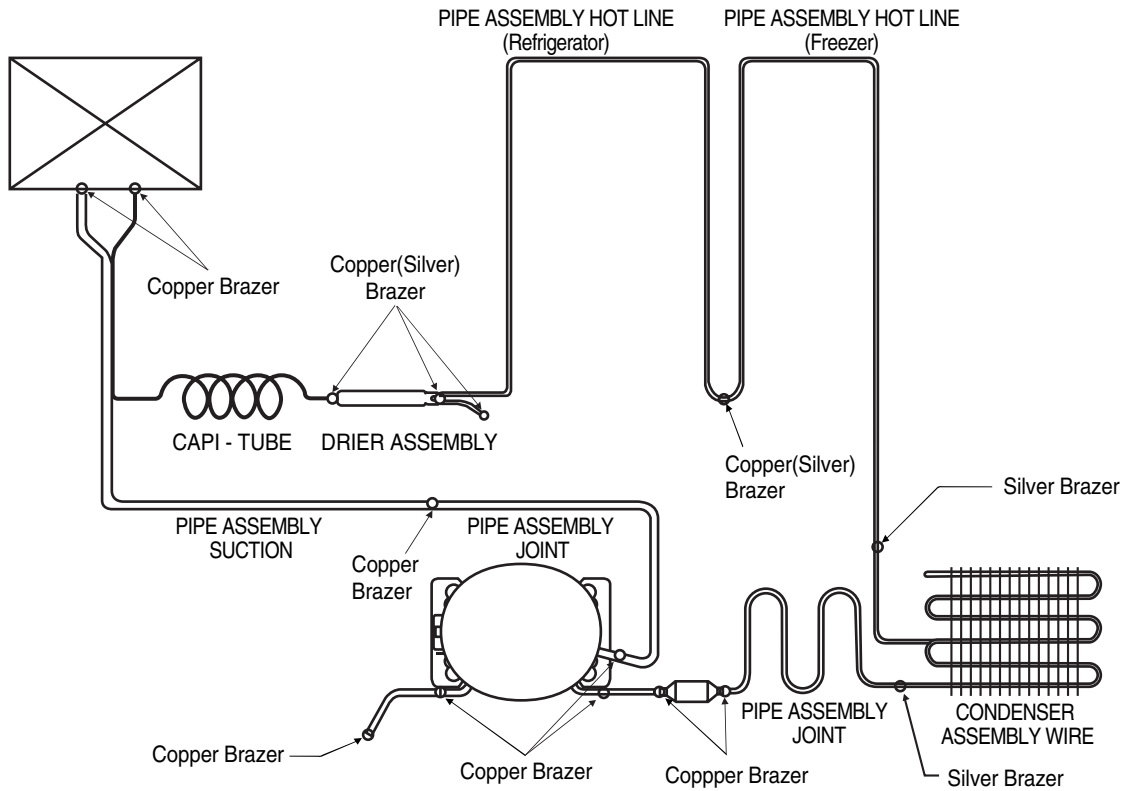

2) Europe & CIS / America

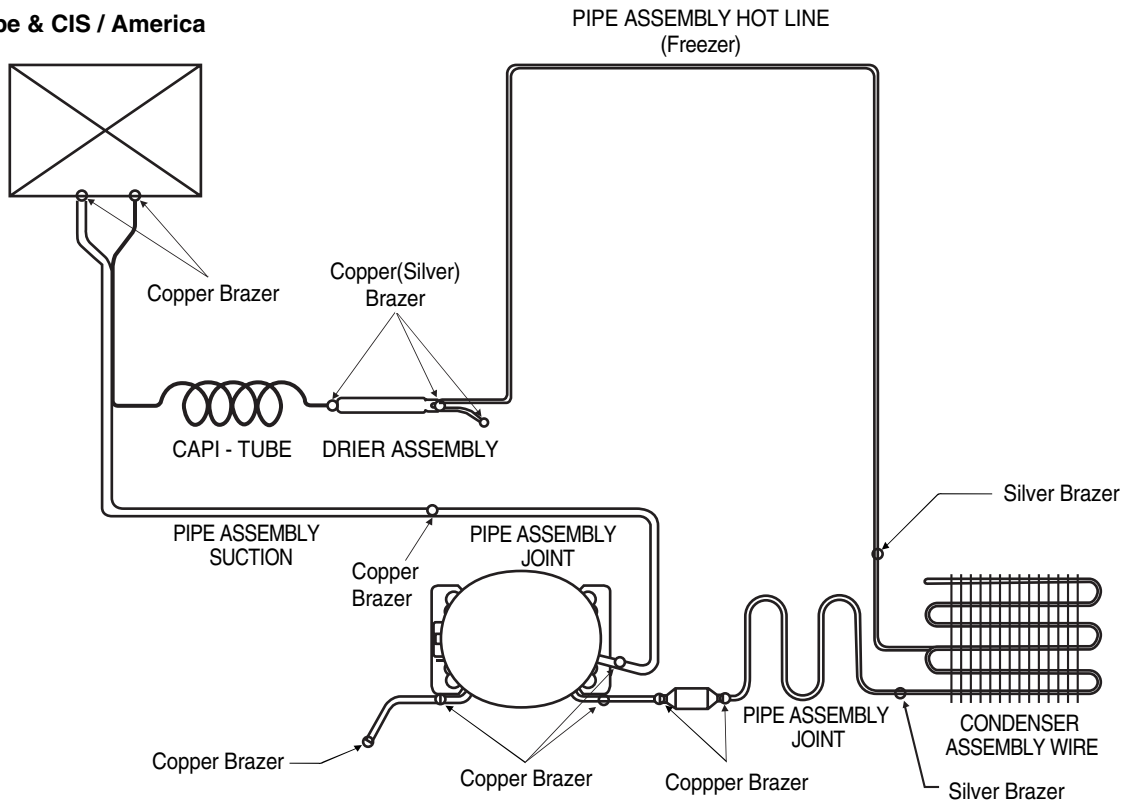

TROUBLE DIAGNOSIS

4. HOW TO DEAL WITH CLAIMS

4-1. Sound

Problems	Checks and Measures
"Whizz" sounds	<ul style="list-style-type: none"> ■ Explain general principles of sounds. <ul style="list-style-type: none"> • All refrigerator when functioning properly have normal operating sound. The compressor and fan produce sounds. There is a fan in the freezer compartment which blows cool air to freezer and refrigerator compartments. "Whizz" sounds are heard when the air passes through the narrow holes into the freezer and refrigerator compartments. ■ Cooling Fan sound in the compressor compartment. <ul style="list-style-type: none"> • There is a fan on the back of the refrigerator, which cools the compressor compartment. If there is a small space between the refrigerator and the wall, the air circulation sounds may be noticeable. ■ Noise of Compressor. <ul style="list-style-type: none"> • This operating sound happens when the compressor compresses the refrigerant. The compressor rotates at 3600RPM. The sound of compressor operation becomes louder as the refrigerator capacity increases.
"Click" sounds	<ul style="list-style-type: none"> ■ Explain the principles of temperature change. <ul style="list-style-type: none"> • The sounds happens when pipes and internal evaporator in the refrigerator compartment expand and contract as the temperature changes during the refrigerator operation. This sound also happens during defrosting, twice a day, when the ice on the evaporator melts.
"Clunk" sound	<ul style="list-style-type: none"> ■ Explain that it comes from the compressor when the refrigerator starts. <ul style="list-style-type: none"> • When the refrigerator operates, the piston and motor in the compressor rotate at 3600RPM. This sound is caused by the vibration of motor and piston when they start and finish their operation. This phenomena can be compared with that of cars. When the car engine ignites and starts to rotate, the loud sound becomes gradually quiet. When the engine stops, it stops with vibration.
Vibration sound	<ul style="list-style-type: none"> ■ Check the sound whether it comes from the pipes vibration and friction. <ul style="list-style-type: none"> • Insert rubber or leave a space between pipes to avoid the noise. • Fix the fan blade if the noise is due to the collision of fan and shroud. • Fix the drip tray if it is loosened. ■ Sound depends on the installation location. <ul style="list-style-type: none"> • Sound becomes louder if the refrigerator is installed on a wooden floor or near a wooden wall. Move it to the another location. • If the refrigerator is not leveled properly, a small vibration can make a loud sound. Please adjust the level of the refrigerator.

TROUBLE DIAGNOSIS

Problems	Checks and Measures
<p>Sounds of water flowing</p>	<p>■ Explain the flow of refrigerant.</p> <ul style="list-style-type: none"> • When the refrigerator stops, the water flowing sound happens. This sound happens when the liquid or vapor refrigerant flows from the evaporator to compressor.
<p>"Click" sounds</p>	<p>■ Explain the characteristics of moving parts.</p> <ul style="list-style-type: none"> • This noise comes from the MICOM controller's switch on the top of the refrigerator when it is turned on and off.
<p>Noise of ice maker operation (applicable to model with ice maker).</p> <ul style="list-style-type: none"> - Noise produced by ice dropping and hitting ice bank. - Noise from motor sounds "Whizz". 	<p>■ Explain the procedure and principles of ice maker operation.</p> <ul style="list-style-type: none"> • Automatic ice maker repeats the cycle of water supplying → icemaking → ice ejection. When water is supplied, the water supply valve in the machine room makes sounds like "Whizz" and water flowing also makes sound. When water freezes to ice, freezing sounds such as "click, click" are heard. When ice is being ejected, sounds like "Whizz" produced by a motor to rotate an ice tray and ice dropping and hitting ice bank sounds are also heard.
<p>Noise when supplying water.</p>	<p>■ Explain the principles of water supplied to dispenser.</p> <ul style="list-style-type: none"> • When the water supply button in the dispenser is pressed, the water supply valve in the compressor compartment opens and let the water flow to the water tank in the lower part of the refrigerator compartment. The water is dispensed by this pressure. When this happens, motor sound and water flowing sound are heard.
<p>Noise when supplying ice.</p>	<p>■ Explain the principles of ice supply and procedure of crushed ice making in a dispenser.</p> <ul style="list-style-type: none"> • When ice cube button is pressed, ice stored in the ice bank is moved by a Helix Pusher and dispensed. If crushed ice button is pressed, the cube ice is crushed. When this happens, ice crushing and hitting ice bank sounds are heard.

TROUBLE DIAGNOSIS

4-2. Measures for Symptoms on Temperature

Problems	Checks and Measures
Refrigeration is weak.	<p>■ Check temperature set in the temperature control knob.</p> <ul style="list-style-type: none"> • Refrigerator is generally delivered with the button set at “normal use” (MID). But customer can adjust the temperature set depending on their habit and taste. If you feel the refrigeration is weak, then set the temperature control button at “strong” position. If you adjust the button in the freezer compartment as well, the refrigeration is stronger than adjusting refrigerator only.
The food in the chilled drawer is not frozen but defrosted	<p>■ The chilled drawer does not freeze food.</p> <ul style="list-style-type: none"> • Use chilled drawer for storing fresh meat or fish for short periods. For storing for a long periods or freezing food, use a freezer compartment. It is normal that frozen foods thaw above the freezing temperature (in the chilled drawer).
Refrigerator water is not cool.	<p>■ Check the water storage location.</p> <ul style="list-style-type: none"> • If water is kept in the door rack, please ask to keep it in the refrigerator compartment shelf. It will then become cooler.
Ice cream softens.	<p>■ Explain the characteristics of ice cream.</p> <ul style="list-style-type: none"> • The freezing point of ice cream is below -15°C. Therefore ice cream may melt if it is stored in the door rack. • Store ice cream in a cold place or set the temperature control button of a freezer at “strong” position.
Refrigeration is too strong.	<p>■ Check the position of temperature control button.</p> <ul style="list-style-type: none"> • Check if refrigeration is strong in whole area of the refrigerator or partly near the outlet of the cooling air. If it is strong in whole area, set the control button at “weak”. If it is strong only near the outlet of cool air, keep food (particularly wet and easy to frozen such as bean curd and vegetables) away from the outlet.
Vegetables are frozen.	<p>■ Check the vegetables storage.</p> <ul style="list-style-type: none"> • If vegetables are stored in the refrigerator shelf or chilled drawer instead of vegetable drawer, they will be frozen. Set the control button at “weak” if they are also frozen in the vegetable drawer.
The food stored at inside of the shelf freezes even the control button is set at “MID”.	<p>■ Check if food is stored near the outlet of the cooling air.</p> <ul style="list-style-type: none"> • The temperature at cooling air outlet is always below the freezing point. Do not store food near the outlet of the cooling air as it block the air circulation. And do not block the outlet. If the outlet of the cooling air is blocked, the refrigerator compartment will not be cooled.

TROUBLE DIAGNOSIS

4-3. Odor and Frost

Problems	Checks and Measures
Odor in the refrigerator compartment.	<p>■ Explain the basic principles of food odor.</p> <ul style="list-style-type: none"> • Each food has its own peculiar odor. Therefore it is impossible to prevent or avoid food odor completely when food is stored in the completely sealed refrigerator compartment. Deodorizer can absorb some portions of the odor but not completely. The intensity of odor depends on refrigerator conditions and environments. <p>■ Check the temperature control button and set at “strong”.</p> <ul style="list-style-type: none"> • Clean inside of the refrigerator with detergent and remove moisture. Dry inside the refrigerator by opening the door for about 3 or 4 hours and then set the temperature control button at “strong”.
Frost in the freezer compartment	<p>■ Explain the basic principles of frost formation.</p> <ul style="list-style-type: none"> • The main causes for frosting: <ul style="list-style-type: none"> - Door was left open. - Air penetration through the gasket - Too frequent door opening. (parties. etc.) - Hot foods are stored before they are cooled down. The temperature of freezer is -19°C. if temperature is set at “MID”. If hot air comes into the refrigerator, fine frost forms as cold air mixes with hot air. If this happens quite often, much frost forms inside of the refrigerator. If the door is left open in Summer, ice may form inside of the refrigerator.
Frost in ice tray.	<p>■ Explain basic principles of frost formation.</p> <ul style="list-style-type: none"> • When ice tray with full of water is put into a freezer compartment, the water evaporates. If cool air fan operates, the moisture attached to the jaw (protruded part) of ice mold shall freeze and form frost. If warm water was put into the ice mold, the situation will become worse.

TROUBLE DIAGNOSIS

4-5. Others

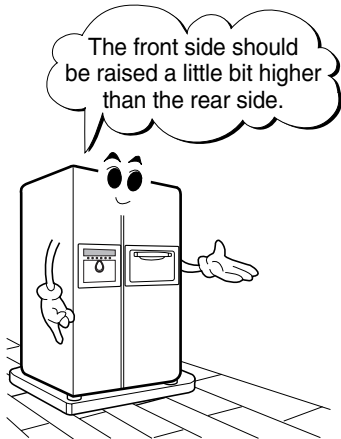
Problems	Checks and Measures
The refrigerator case is hot.	<ul style="list-style-type: none"> ■ Explain the principles of radiator. <ul style="list-style-type: none"> • The radiator pipes are installed in the refrigerator case and partition plate between the refrigerator and the freezer compartment in order to prevent condensation formation. Particularly in summer or after installation of refrigerator, it may feel hot but it is normal. If there is no enough space to dissipate heat, it can be hotter due to lack of heat radiation. Please install a refrigerator in a well-ventilated place and leave a clearance between refrigerator and wall:
Small holes in a door liner	<ul style="list-style-type: none"> ■ Explain that the hole is for releasing gas. <ul style="list-style-type: none"> • A small hole in the door liner is for releasing gas during insulation materials lining work. With a releasing hole, forming can be easily done .
Electric bills are too much.	<ul style="list-style-type: none"> ■ Check the use conditions. <ul style="list-style-type: none"> • Too frequent door opening and hot food storing cause the compressor to operate continuously and hence increase the electric consumption and bills.
Condensation on the inside wall of the refrigerator compartment and the cover of properly vegetable drawer.	<ul style="list-style-type: none"> ■ Explain how to store foods <ul style="list-style-type: none"> • Condensation forms when refrigerator is installed at damp area, door is frequently opened, and wet foods are not stored in the air tight container or wrapped. Be sure to store wet foods in the air tight container or in the wrap.
When is the power connected?	<ul style="list-style-type: none"> ■ When should the power be connected ? <ul style="list-style-type: none"> • You can connect the power right after the installation. But if the refrigerator was laid flat during transportation for a long period of time and the refrigerant and compressor oils are mixed up, then this will affect badly the performance of a refrigerator. Be sure to connect the power 2~3 hours after refrigerator is installed.
Door does not open properly. 	<ul style="list-style-type: none"> ■ Refrigerator compartment door does not open properly. <ul style="list-style-type: none"> • When the door is open, warm open air comes into the compartment and is mixed up with cool air. This mixed air shall be compressed and increase the internal pressure when door is closed. This causes the door stucked closely to the refrigerator in a moment. (If the refrigerator is used for a long time, it will then open smoothly.) ■ When the refrigerator compartment door is open and close, the freezer compartment door moves up and down. <ul style="list-style-type: none"> • When the refrigerator compartment door is open and close, fresh air comes into the freezer compartment and moves up and down the freezer compartment door. ■ Door opens too easily. <ul style="list-style-type: none"> • There is a magnet in the gasket rubber so that it is ok. if door is securely closed without a gap. It can be open easily if the foods in the refrigerator or freezer compartments hold the door open. ■ A door does not close properly. <ul style="list-style-type: none"> • If the rear side of the refrigerator is raised higher than front side, door shall not be easily closed. Adjust the level of refrigerator with levelling screws.

HOW TO DISASSEMBLE AND ASSEMBLE

1. DOOR

1) Remove lower cover and then disconnect water supply tube in the lower part of freezer door.

- Pull a water supply tube ② forward while pressing ① part to disconnect water supply tube as shown below.

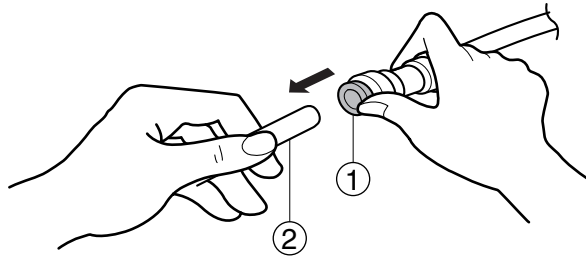

2) Remove a freezer door.

- (1) Loosen hinge cover screw of freezer door and remove cover. Disconnect all connecting lines except earthing cord.

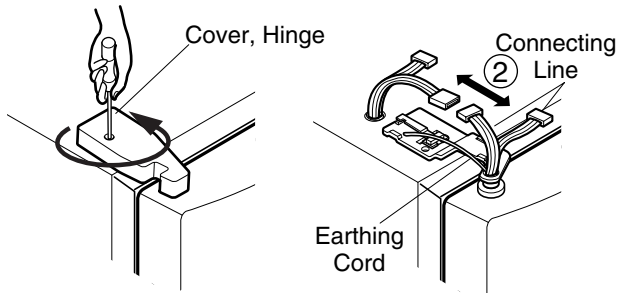

- (2) Turn hinge lever in arrow (A) direction until it is loosened and take it out in arrow (B) direction.

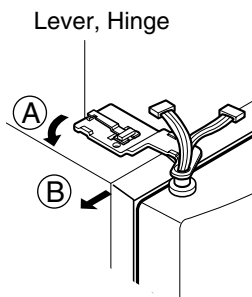

Note : • When disconnecting refrigerator door, turn hinge lever counterclockwise.

- If hinge lever or bracket hinge pin is deformed during assembling freezer and refrigerator doors, fix two screws (Tap Tite Screw, M6: Hinge, L fixing screw) in the hole of upper hinge.

- (3) Disconnect upper hinge ① from a hinge supporter ② by grasping the front part of upper hinge and lifting up (Hinge Assembly, U) in arrow direction (A) and pull forward in arrow (B) direction. Be careful as the door may be fallen down.

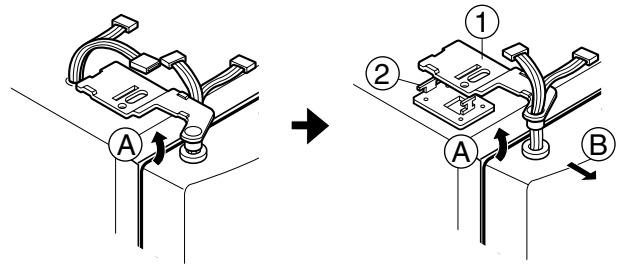

- (4) Lift up the freezer door ① in arrow direction and disconnect the door from the lower hinge ②. Don't pull a door forward.

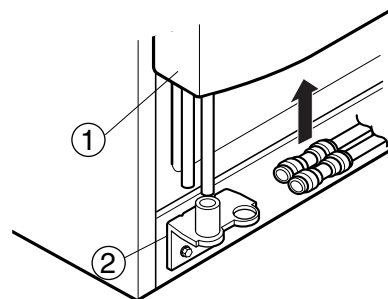

Note : • Lift up a freezer door until a water supply tube is fully taken out.

- (5) Assembly is the reverse order of disassembly

HOW TO DISASSEMBLE AND ASSEMBLE

2. HANDLE

- 1) Put blade screwdriver into a groove on the side of a Deco handle and lift up a little bit in arrow ① direction and push up with hand in arrow ② direction and disconnect.

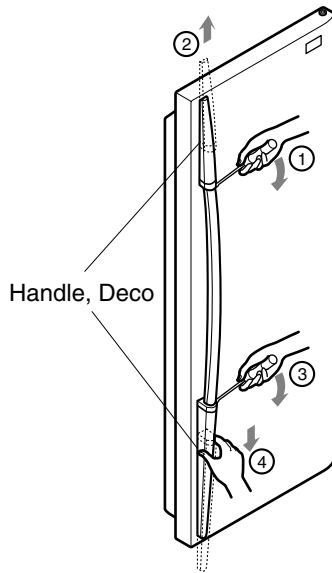

- 2) Put blade screwdriver into a groove on the side of a DECO handle and lift up in arrow direction ③ and push down with hand in arrow direction ④ and disconnect.
- 3) Push up a piece handle ③ in arrow direction with hand and disconnect.
- 4) Turn screw in arrow direction with a cross driver and disconnect.

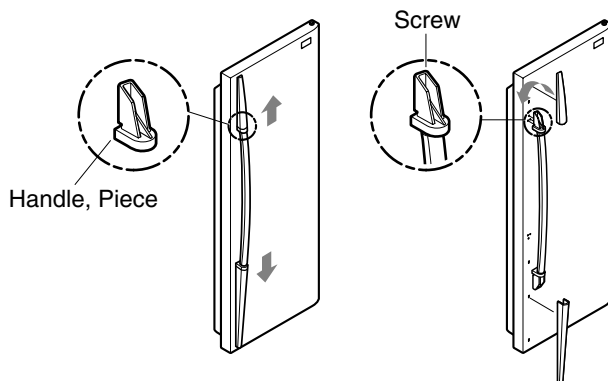

3. SHROUD, GRILLE FAN

- 1) Loosen two screws after disconnecting a cap screw of a grille fan(U) with a blade screwdriver.
- 2) Disassembly of a grille fan(U) : Pull forward after opening hook at → part with a blade screwdriver.
- 3) Disconnect housing A of a grille fan (L) from the main body.
- 4) Disassembly of a grille fan (L) : Hold upper part of a grille fan(L) and pull forward carefully.
- 5) Loosen two screws.
- 6) Disassembly of shroud. F(U) : Disconnect housing of B after removing two rail guides with a blade screwdriver.
- 7) Disassembly of shroud. F(U) : Hold upper part and pull forward.
- 8) Check foam PU sticking conditions around a shroud, F(U) and F(L) during assembling. If damaged, torn or badly stuck, assemble with a new one after sealing well.

HOW TO DISASSEMBLE AND ASSEMBLE

4. WATER VALVE DISASSEMBLY METHOD

- 1) Turn off the power of the refrigerator (pull out the plug). Open the FREEZER and REFRIGERATOR Door and disassemble the Lower Cover.



- 2) Lay a dry towel on the floor and get ready to spill water from the water tank. Pull out the Clip. Then press the collet to separate the tube from the connector and pour out the water until emptied. (Refer to the label attached on Front L on how to separate the tube.)

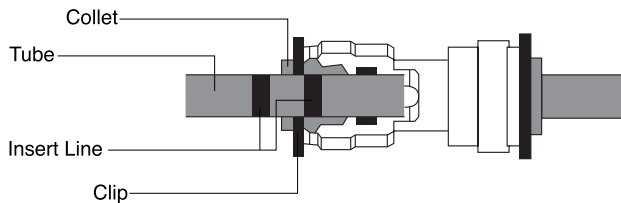

- 3) Turn off the water. Then separate the water line from the valve.



- 4) Separate the Mechanical Cover and Valve Screw.



- 5) Separate the housing and pull out the valve.

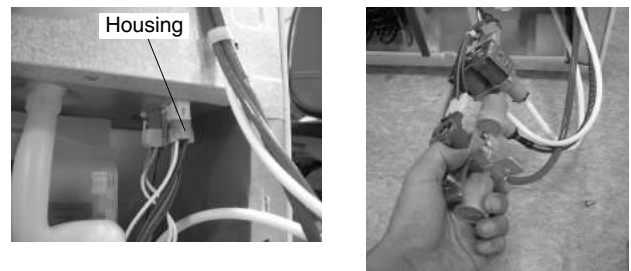

5. FAN AND FAN MOTOR DISASSEMBLY METHOD

- 1) Using a short screwdriver, loosen one SCREW in DRAIN PIPE ASSEMBLY and one connected to the MOTOR COVER.

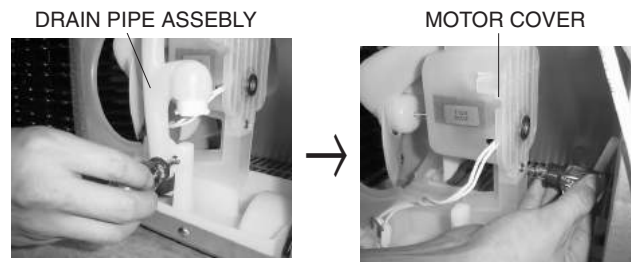

- 2) Pull and separate the FAN ASSEMBLY and MOTOR turning counterclockwise based on the MOTOR SHAFT.

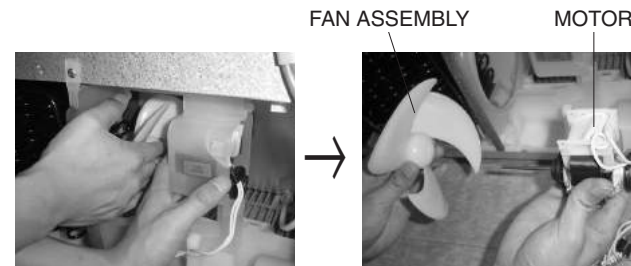

The assembly is in the reverse order of the disassembly and take special care for the following details.

1. Be careful not to bend the tube during assembly.
2. Press the WATER DISPENSER button until water pours out and check for leakage in the CONNECTOR TUBE (It differs by the water pressure but usually takes about 2 minutes until water pours out.)

HOW TO DISASSEMBLE AND ASSEMBLE

6. DISPENSER

1) Disconnect funnel and button assembly by pulling down and forward.

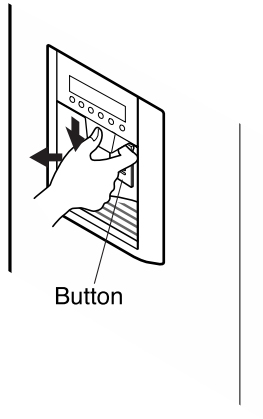

4) Loosen four screws with a phillips screwdriver and pull the funnel assembly to disconnect.

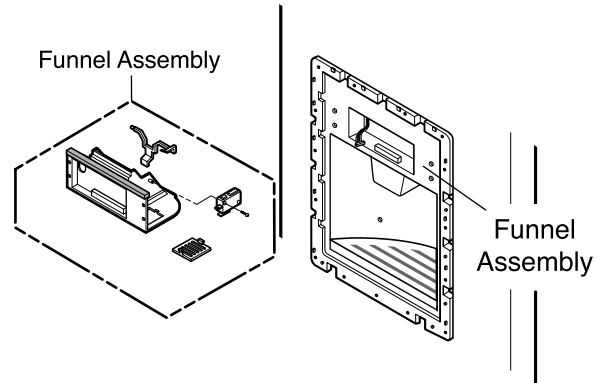

2) Remove display frame assembly by making a gap between a display frame assembly and door with a flat blade screwdriver and pulling it forward. The cover dispenser is attached with a hook.

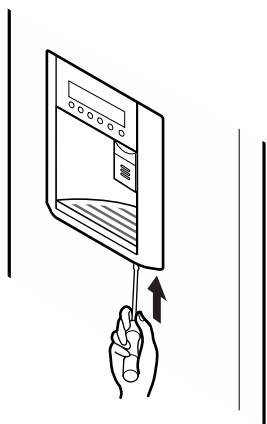

5) The duct cap assembly can be disconnected if the hold lever connecting screw is loosened with a phillips driver.

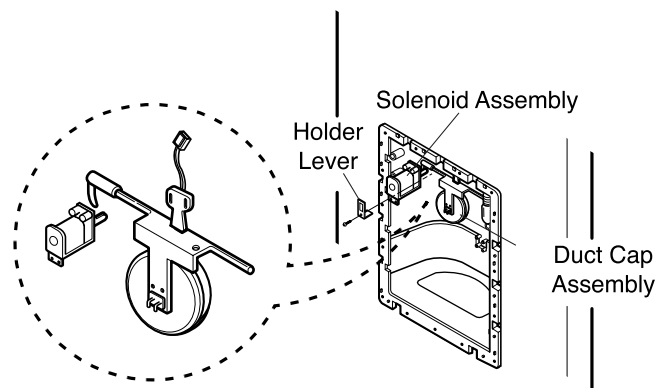

3) The display assembly can be connected by pressing the top of the dispenser cover and pushing it after separating the display frame from its housing.

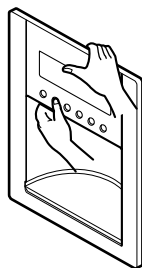

6) To install the duct cap assembly, insert one end of the spring into the right hole of the dispenser lever and insert the other end into the right hole in the top part of the dispenser. Then attach the holder at the solenoid switch.

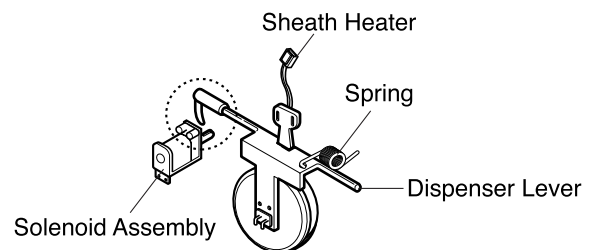

HOW TO DISASSEMBLE AND ASSEMBLE

7) Dispenser Related Parts

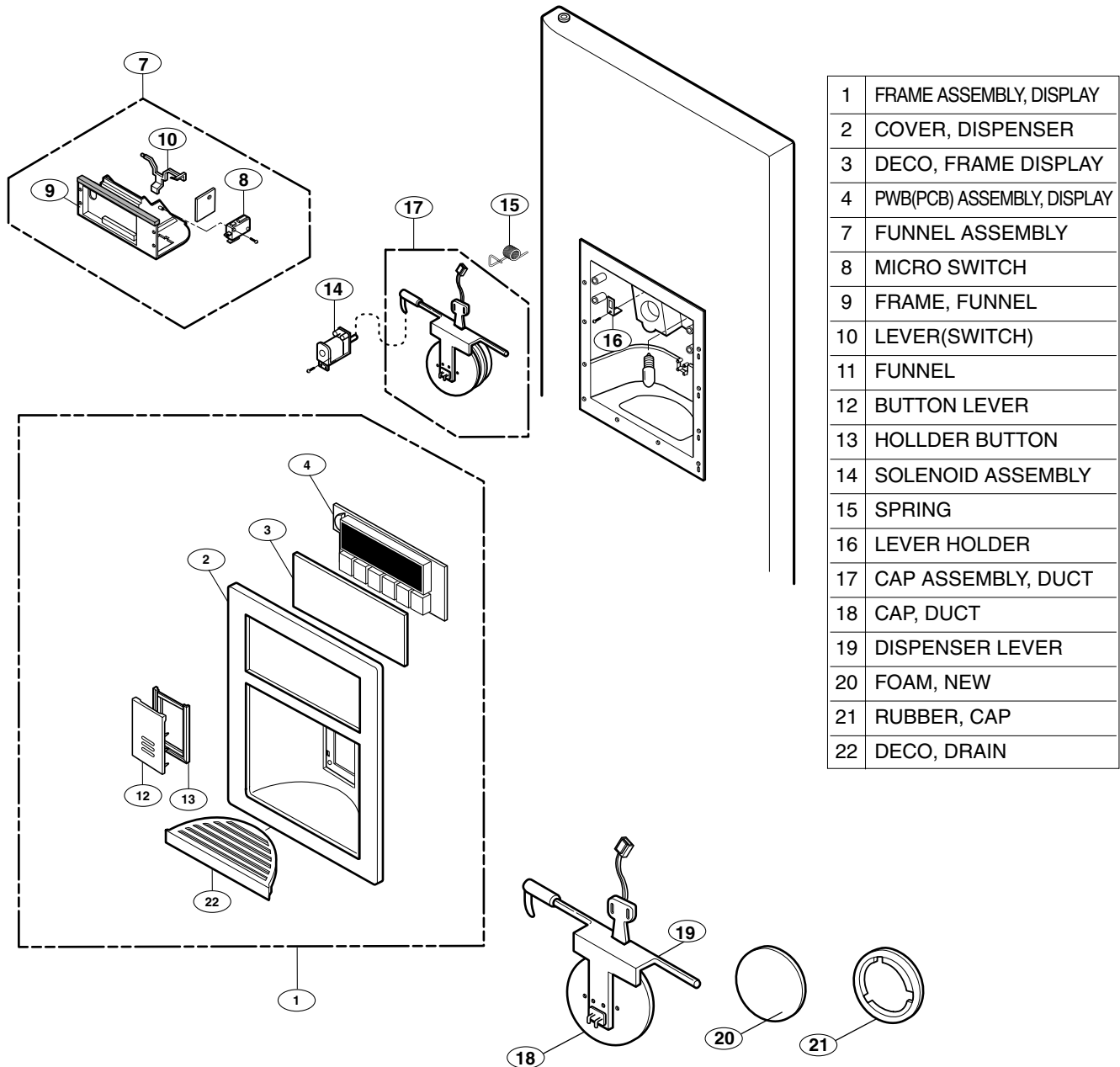

NOTE : Not every model includes every option

EXPLODED VIEW

FREEZER DOOR PART: GR-P227/L227/P257/L257

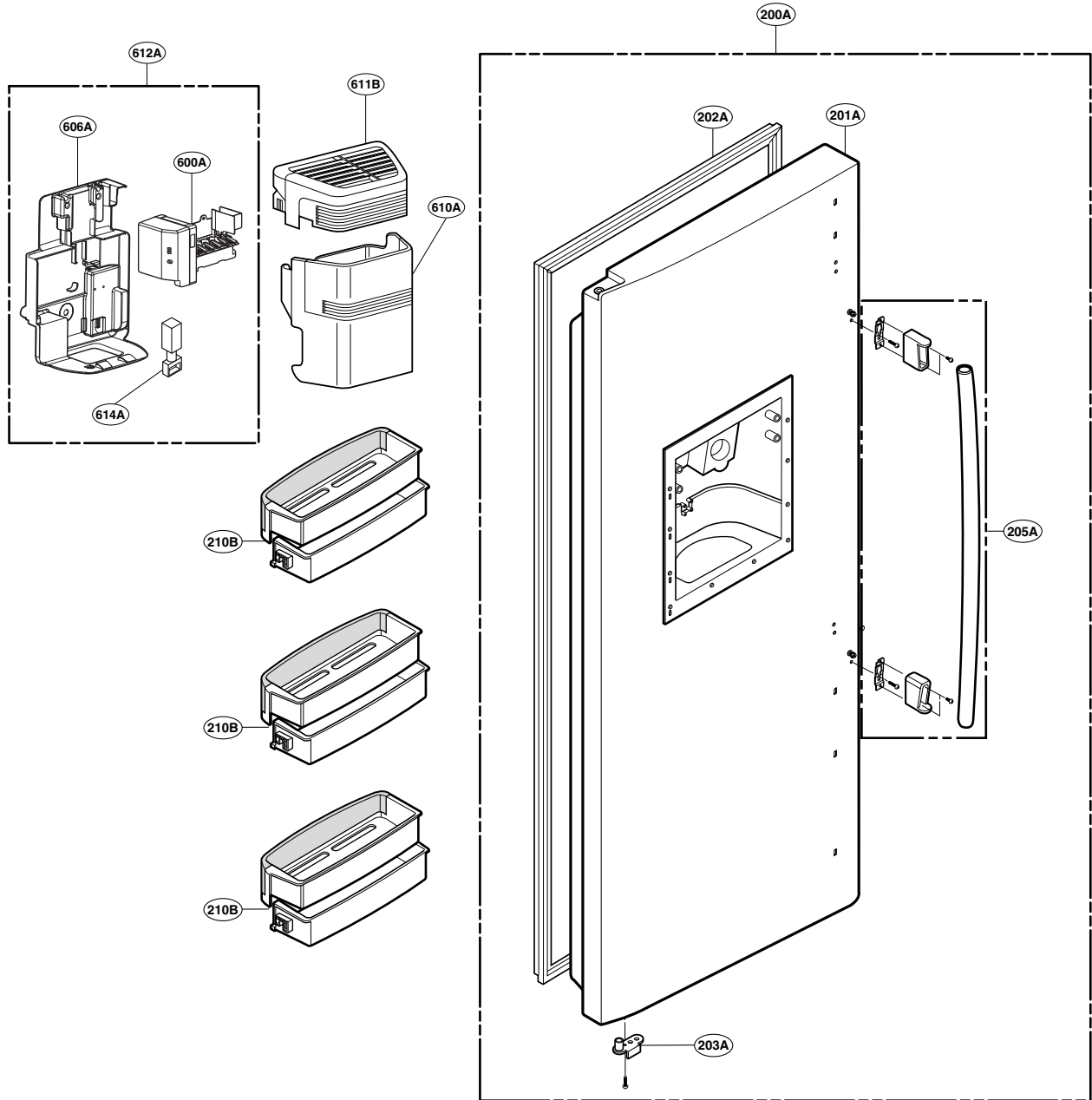

EXPLODED VIEW

Ref No. : GR-P227/GR-P257
REFRIGERATOR DOOR PART

* : Optional part

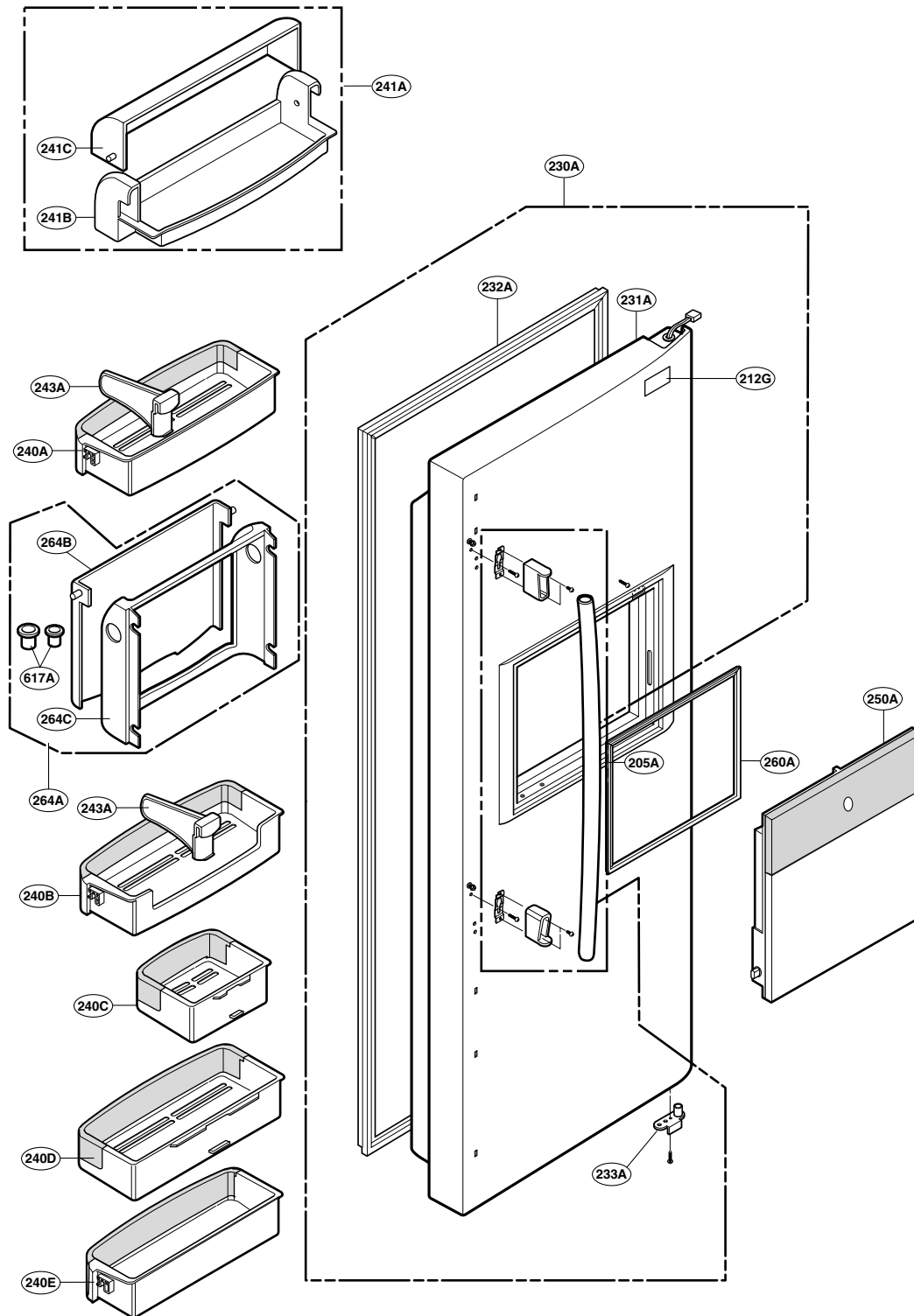

EXPLODED VIEW

Ref No. : GR-L227/GR-L257
REFRIGERATOR DOOR PART

* : Optional part

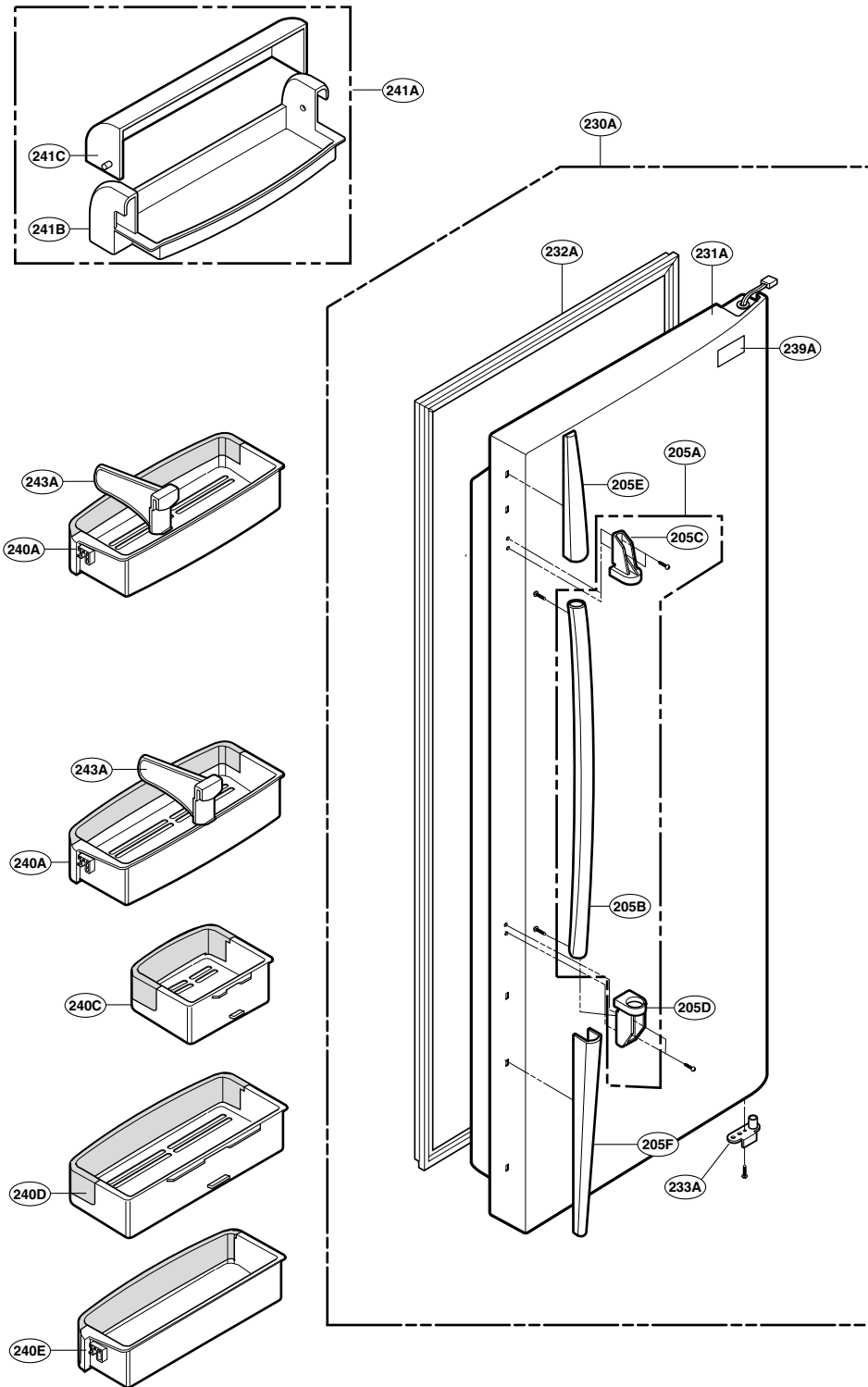

EXPLODED VIEW

FREEZER COMPARTMENT

* : Optional part

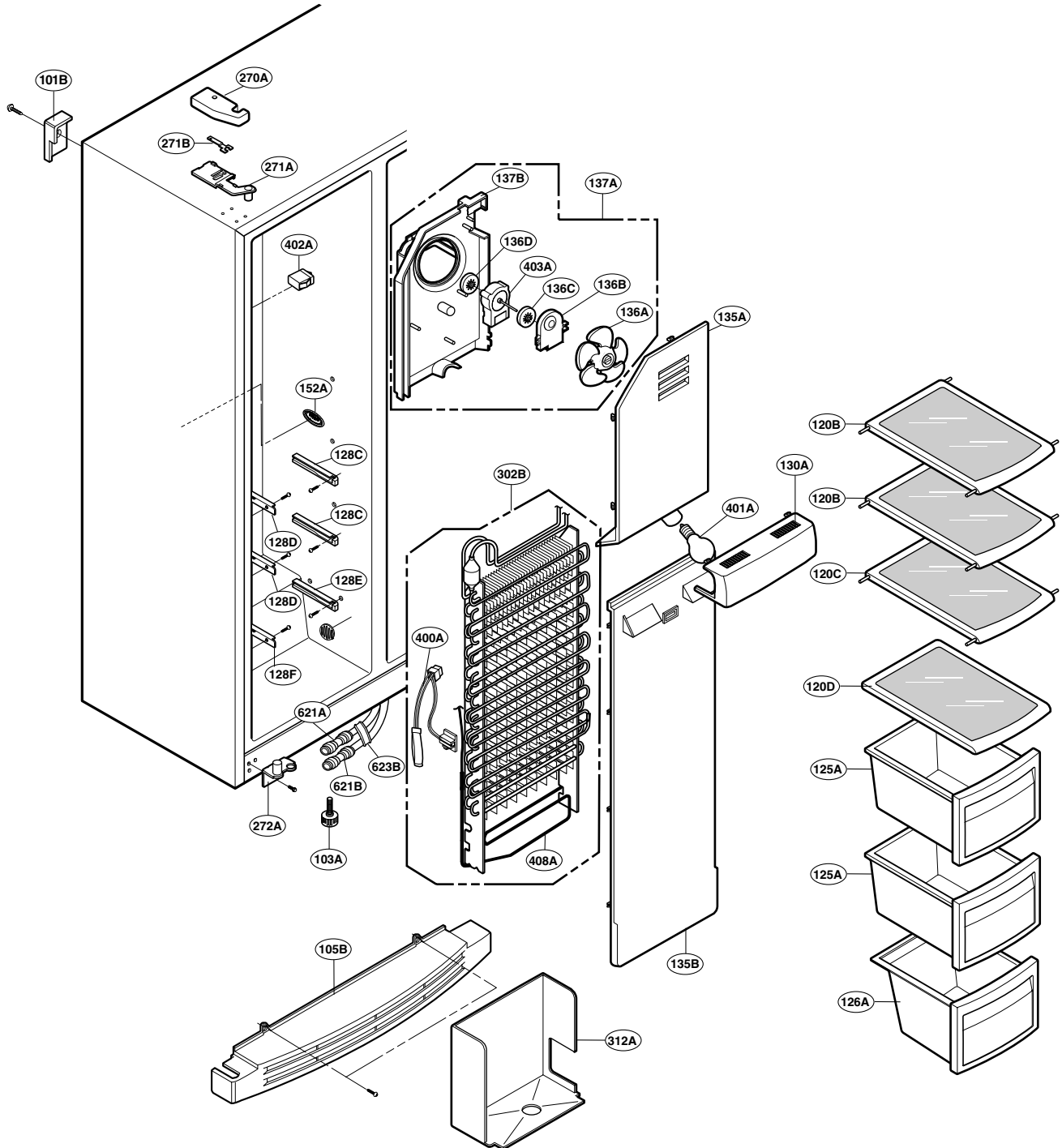

EXPLODED VIEW

REFRIGERATOR COMPARTMENT

* : Optional part

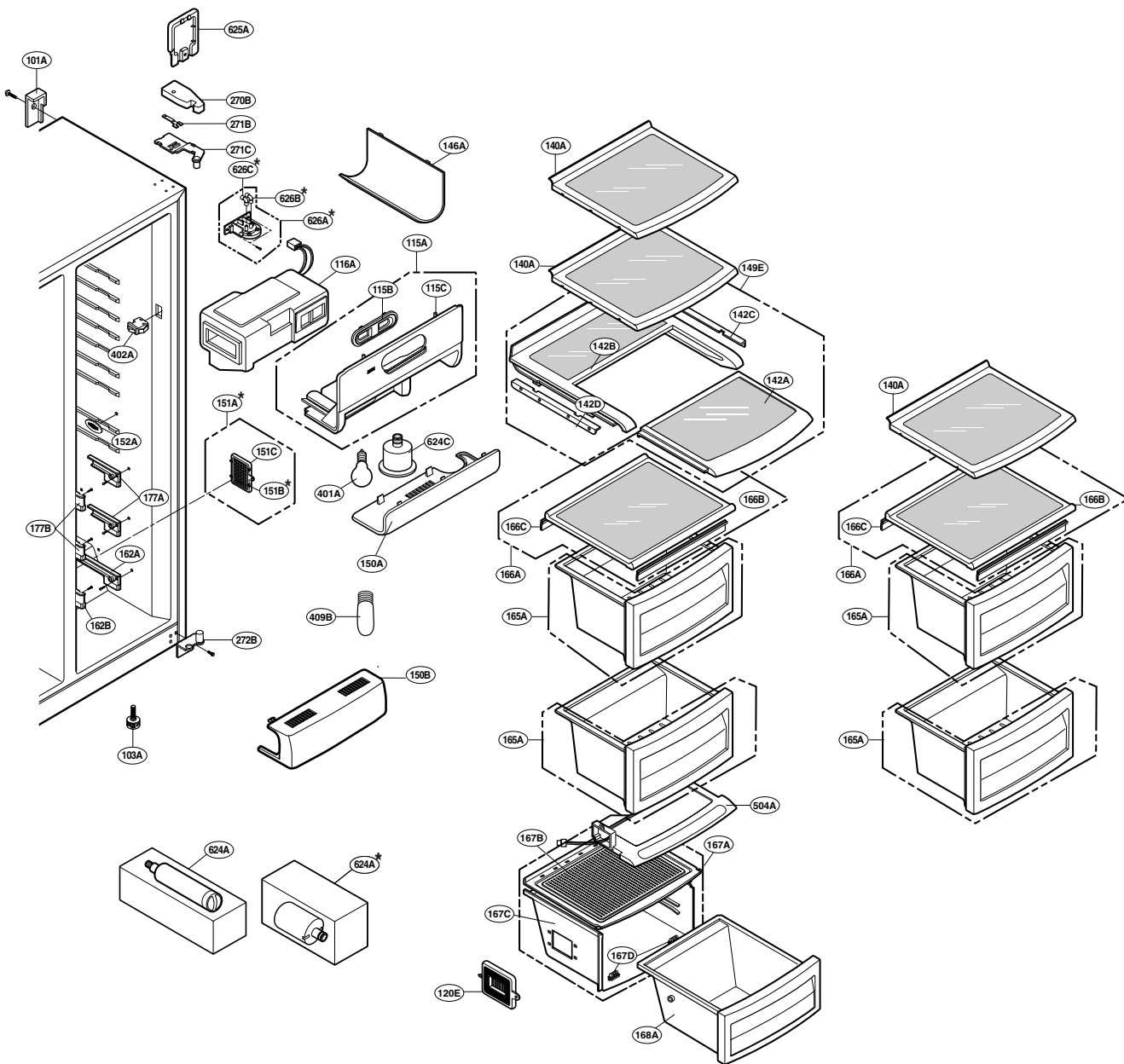

EXPLODED VIEW

MACHINE COMPARTMENT

* : Optional part

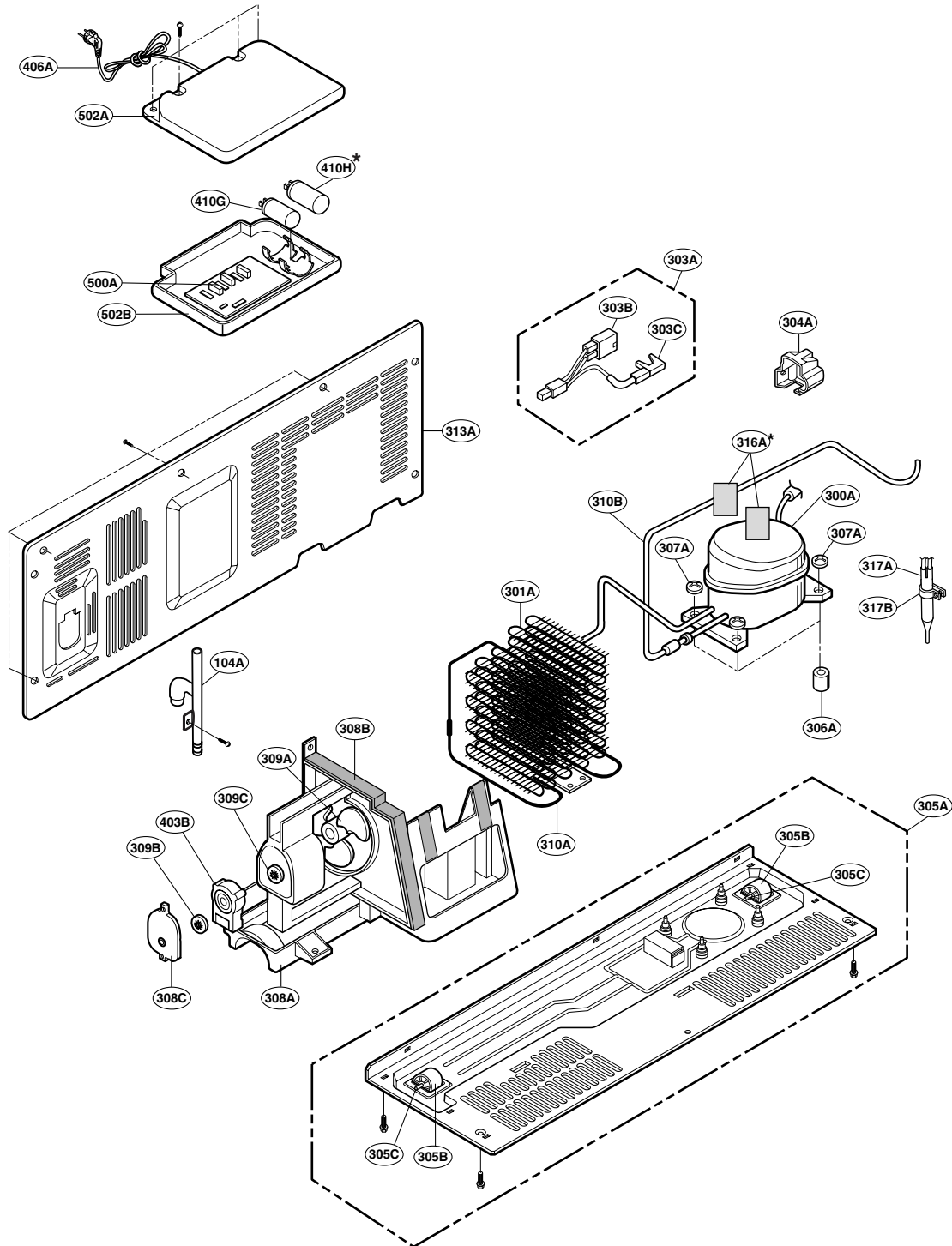

EXPLODED VIEW

ICE & WATER PART

* : Optional part

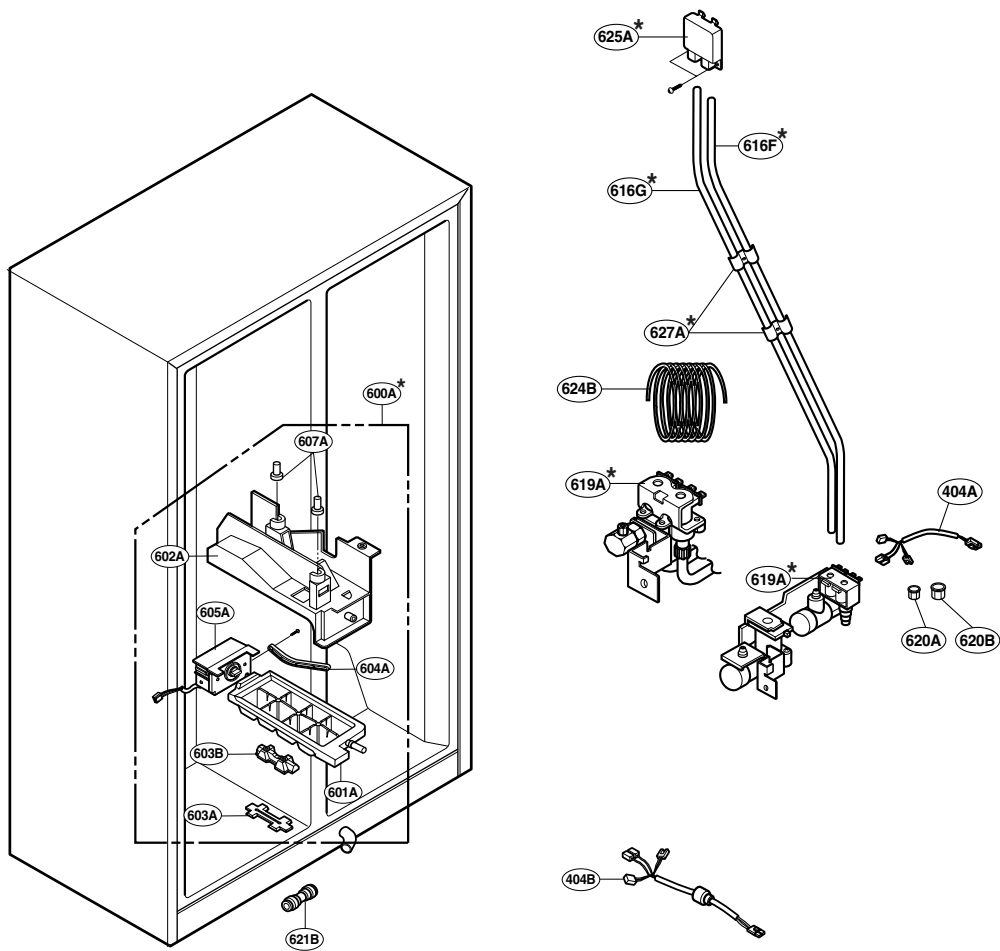

EXPLODED VIEW

DISPENSER PART

* : Optional part

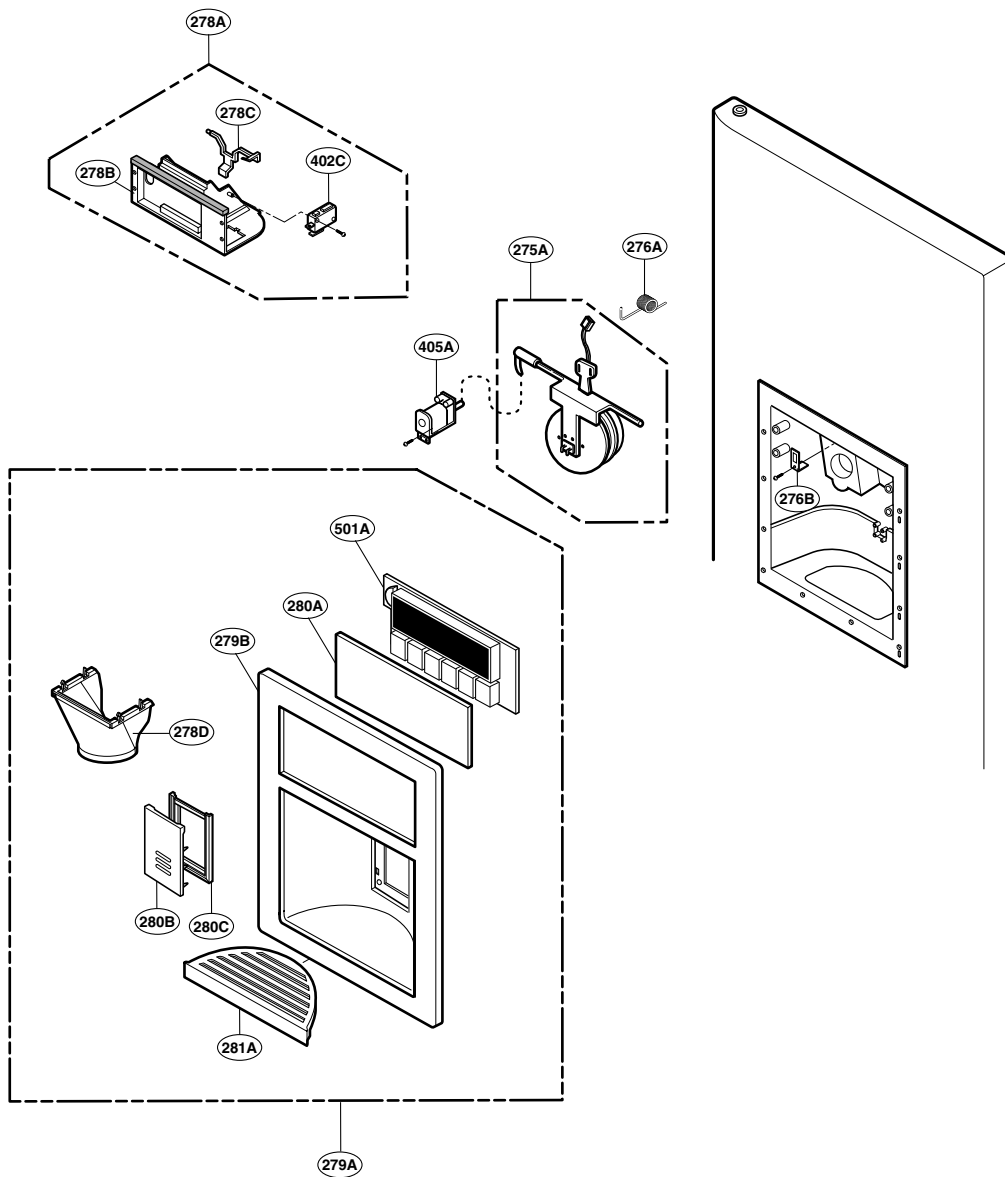



P/No. 3828JD8999A

FEB., 2006 Printed in Korea